



D60 Vacuum Pump and Compressors Series

User Guide

Issue 07
Date 2020-06



Copyright © Chengdu Hilin Technology Co., Ltd. 2020. All rights reserved.

No part of this document may be reproduced or transmitted in any form or by any means without prior written consent of Chengdu Hilin Technology Co., Ltd.

Trademarks and Permissions

 is a trademark of Chengdu Hilin Technology Co., Ltd.

All other trademarks and trade names mentioned in this document are the property of their respective holders.

Notice

The purchased products, services and features are stipulated by the contract made between Chengdu Hilin Technology Co., Ltd. and the customer. All or part of the products, services and features described in this document may not be within the purchase scope or the usage scope. Unless otherwise specified in the contract, all statements, information, and recommendations in this document are provided "AS IS" without warranties, guarantees or representations of any kind, either express or implied.

The information in this document is subject to change without notice. Every effort has been made in the preparation of this document to ensure accuracy of the contents, but all statements, information, and recommendations in this document do not constitute a warranty of any kind, express or implied.

Chengdu Hilin Technology Co., Ltd.

Address: No.3663 Section 2 Muhua Road
Shuangliu District
Chengdu Sichuan China 610000

Website: <http://www.hilintec.com>

Tel: +86-28-62567958

About This Document

Purpose

This document is related to the D60 vacuum pump and compressor series products, which is used to guide relevant technical personnel to initially understand the characteristics of the product.

Intended Audience

This document is intended for technical personnel. You should have a good understanding of your product and have a clear concept of the relevant parameters, specifications, and other information of the applications of the micro pump.

Keyword

Remote control, related parameters, wiring instructions

Change History

The change history accumulates each update of this document. The latest version of the document contains all the previous updates.

Issue	Date	Product Version	Issuer	Modification
01	2019-07	1.0	GZM	First official release
02	2019-09	1.0	GZM	Modify ‘ indicator light flashes red’ to ‘indicator light remains red’
03	2019-09	1.0	LYZ	Modify document format
04	2019-12	1.0	FB	Update notes in section 3.1
05	2020-02	1.0	FB	Update drawings of dimensions
06	2020-04	1.0	FB	Update reference curve and correct part of the descriptive information
07	2020-06	1.0	FB	Update medium description

Contents

About This Document	I
Change History	II
Contents	III
1 Characteristics	1
1.1 Working Status Indicator.....	1
1.2 Brush-less DC Motors.....	1
1.3 Protections.....	1
2 Special Features	2
2.1 Working Status Indication and Warning.....	2
3 Technical Specifications	3
3.1 Key Specifications.....	3
3.2 Versions Description.....	3
3.3 Description of Types.....	4
3.4 List of Models Combination for Sale.....	4
3.5 Life-time Test Conditions.....	5
3.6 Working Conditions.....	5
3.7 Pump Materials.....	6
3.8 Parameter Curve.....	6
3.9 Starting Current Curve.....	7
4 Product Model Description	8
4.1 Brief Description of Model Naming.....	8
5 Electrical Connection	9
5.1 Basic Type.....	9
5.2 Remote Control Type.....	9
6 Cautions	11
8 Appearance	15

1 Characteristics



1.1 Working Status Indicator

The remote control type and basic type are equipped with working status indicator lights, which can visually feed back the working status of the pump.

1.2 Brush-less DC Motors

This model is driven by brush-less motors which have the advantages of long service life, low interference and high reliability.

1.3 Protections

Equipped with overheating protection, overload protection, power supply under-voltage and over-voltage protection and reverse connection protection function, which to the greatest extent prevents accidental damage to the pump.

2 Special Features

2.1 Working Status Indication and Warning

1. The basic type and remote control type are equipped with working status indicator lights. Users can understand the working status of the equipment through the color change of the indicator lights:

- a. When the indicator light remains green, it means that the power supply is normal and the pump is not working;
- b. When the indicator light flashes green, it means the pump is working normally;
- c. When the indicator light remains red, it means the pump is working abnormally;
- d. When the positive and negative poles are reversed, the indicator light is off, the pump does not work, but it will not damage the pump.

3 Technical Specifications

3.1 Key Specifications

Model	Voltage (VDC)	Load Current (A)	Flow (L/min)		Relative Vacuum (-kPa)	Maximum Output Pressure (kPa)	Weight (g)
			Peak Flow	Average Flow			
D60L	24	≤1.3	≥26	≥18	≥50	≥100	≈850

Note: 1. The input voltage requires $24V \pm 10\%$.

2. The parameters in the table are measured at the maximum speed of the motor. When the motor speed changes, the pressure/vacuum level is basically unchanged.

3. Unless otherwise specified, the technical parameters are measured under the conditions of temperature 25°C and standard atmospheric pressure of 101kPa . For products with other parameters and specifications, you can contact us to customize.

4. The above parameters are measured under the configuration of standard connectors. If other types of connectors are configured, the parameters may change slightly.

3.2 Versions Description

Version	Simplified Version	Standard Version	Premium Version
Performance			

Lifetime	≥2500h	≥6000h	≥8000h
Noise	★	★★	★★★
Reliability	★	★★	★★★
Parameter consistency	★	★★	★★★
EMC	★	★★	★★★
Ambient temperature	0~40℃	0~50℃	0~50℃

- Note:**
1. The more ★, the better performance of this item.
 2. The noise data of the simplified version and the standard version are not specified. For the noise data of the premium version, please refer to the latest information.

3.3 Description of Types

Types	Function and Configurations
Basic Type	Only equipped with indicator lights and start-stop switch.
Remote Control Type	Besides the indicator light and start-stop switch of the basic type, it is also equipped with a remote control connector, from which the user can control the start and stop of the pump from a remote location. Note: If you want to use the remote control function, the start-stop switch on the panel should be set to the "on" position.

3.4 List of Models Combination for Sale

Type \ Version	Simplified Version	Standard Version	Premium Version
Basic Type	√	Customizable	Customizable

Remote Control Type	√	√	Customizable
Touch Control Type			
Top Configuration Type			

Note: √ in the above table means that there is a corresponding product for sale, unchecked means that there is no corresponding product. (The above table does not include customized products.)

3.5 Life-time Test Conditions

In a clean, non-corrosive laboratory, the pump carries a full load (the outlet is blocked and the inlet directly connected to the atmosphere), and operates continuously around the clock. The ambient temperature is 5°C ~ 33°C, fluctuates with the climate; the relative humidity is 30% ~ 90%, which fluctuates with the climate.

3.6 Working Conditions

1.Environment: Permissible ambient temperature range of the simplified version products is 0 °C ~ 40 °C , and the permissible ambient temperature of the standard and premium versions is 0 °C ~ 50 °C . The permissible relative humidity of all pumps in this series is ≤ 90%, no condensation. The pump should not be exposed to the sun, and should work in a clean and ventilated environment.

2.Medium: Permissible gaseous media temperature range is 0 °C ~ 50 °C . The medium is allowed to be rich in water vapor, but cannot contain particles or oil mist.

3. Load:

1) When used as a compressor: the outlet can run at full load (i.e completely blocked the outlet), but the applied load cannot exceed the maximum discharge pressure of the pump; the inlet must be unobstructed.

2) When used as a vacuum pump: the inlet can operate at full load (i.e completely blocked the inlet), but the applied load cannot exceed the maximum vacuum degree of the pump; the outlet must keep unobstructed.

3.7 Pump Materials

1. The materials of the wetted parts: reinforced nylon, EPDM rubber, nitrile rubber and silicone rubber. Please check the tolerance of the medium according to the wetted material.
2. The material of the plastic parts of the pump body is fiber reinforced nylon, and the material of the shock absorb foot is PVC.

3.8 Parameter Curve

Pressure-flow rate curve, there are individual differences between different micro pumps, so this curve is a statistical value, only as a technical reference for users to confirm the working point. The "flow" mentioned in this section refers to the "average flow".

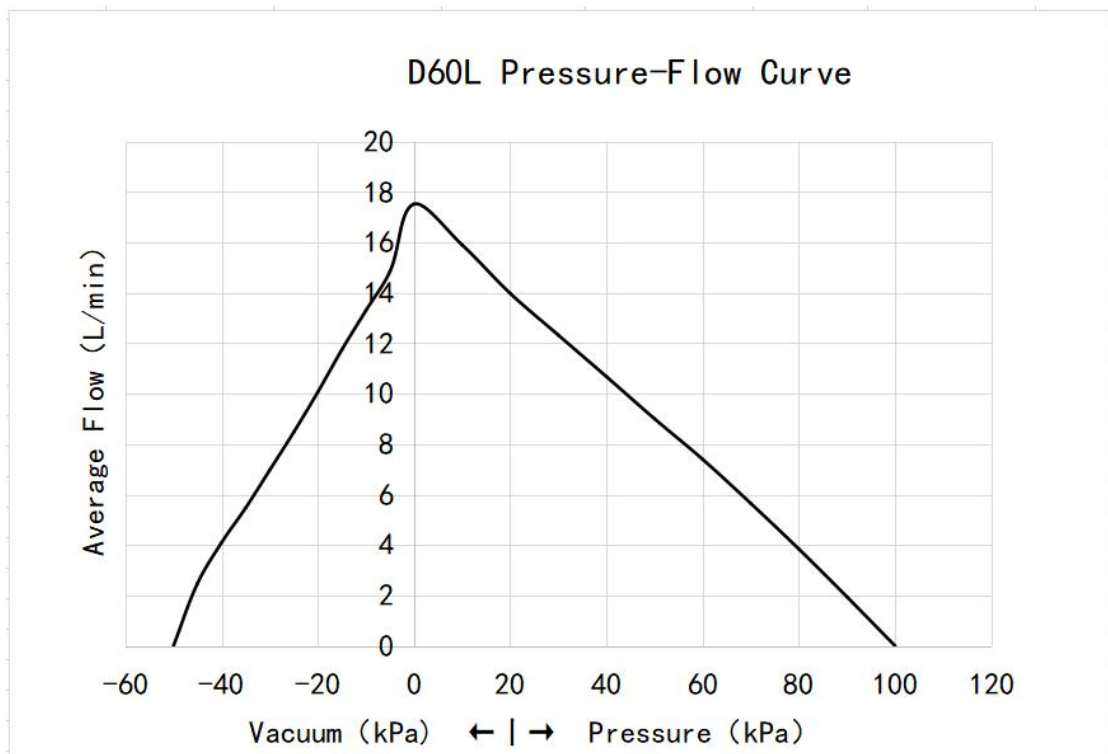

- Note:**
1. The maximum average flow rate of the curve will be slightly lower than the nominal value, which is due to the resistance of the test pipeline components, which leads to the attenuation of the flow;
 2. The value of this curve is for reference only, not as a basis for product acceptance.

3.9 Starting Current Curve

The starting current curve is measured under the working condition that the inlet and outlet are directly connected to the atmosphere, and there are certain individual differences between different micro pumps. This curve is a statistical value, which is only used as a technical reference when users determine the power supply system, and is not for acceptance data.

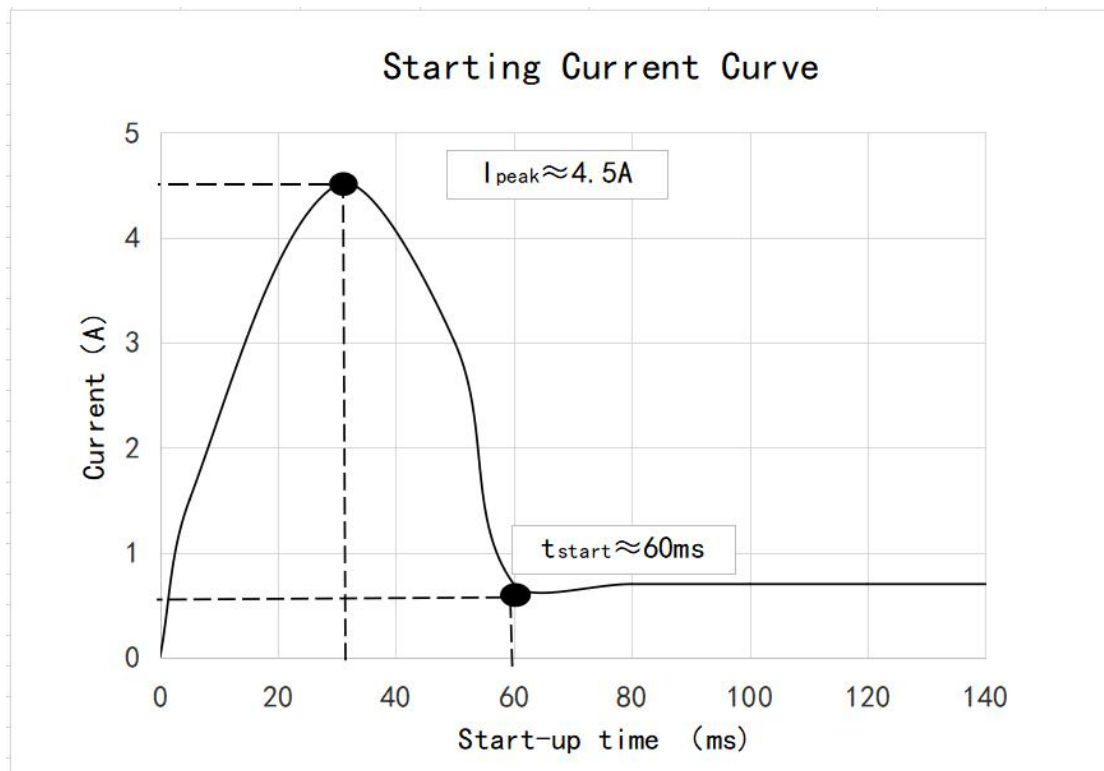

4 Product Model Description

4.1 Brief Description of Model Naming

There are two types of this series of pumps: basic type and remote control type,

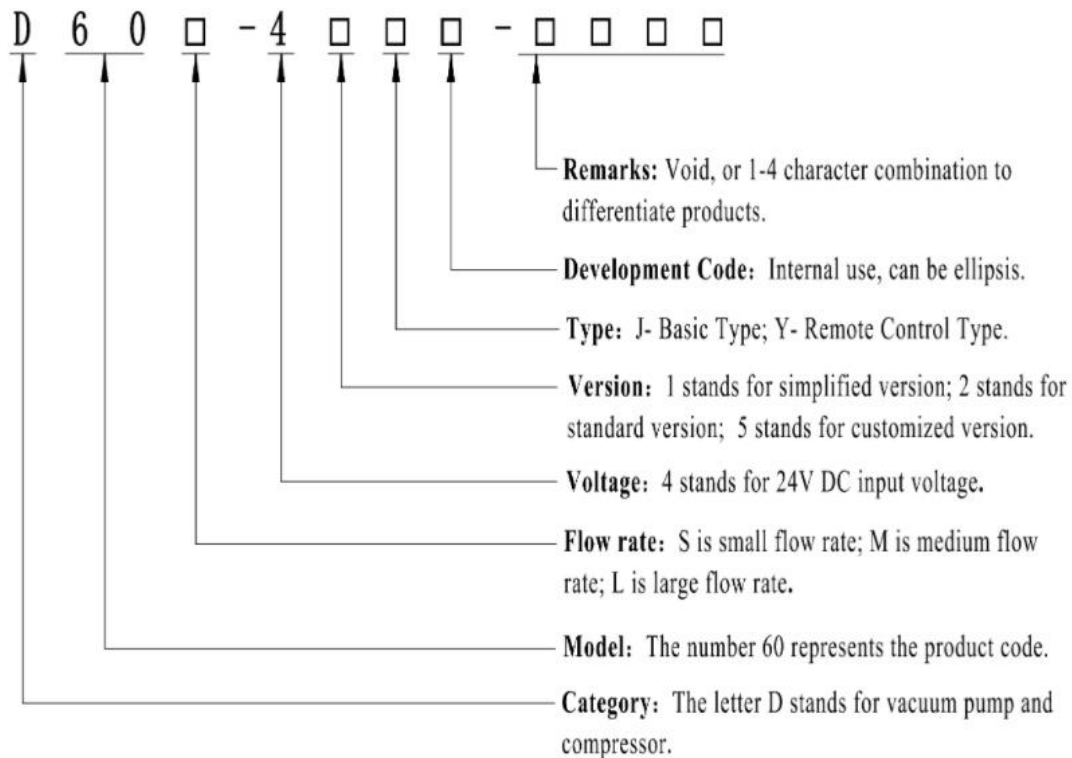

Note: If the remarks starts with a letter, it means a special custom function. For example, letter "GJ" means customized high-temperature medium function, and "GH", means customized high-temperature environment function. If it starts with a number, it means other information.

Example 1: D60L-41J(D60L pump, 24V voltage basic type simplified version)

5 Electrical Connection

5.1 Basic Type

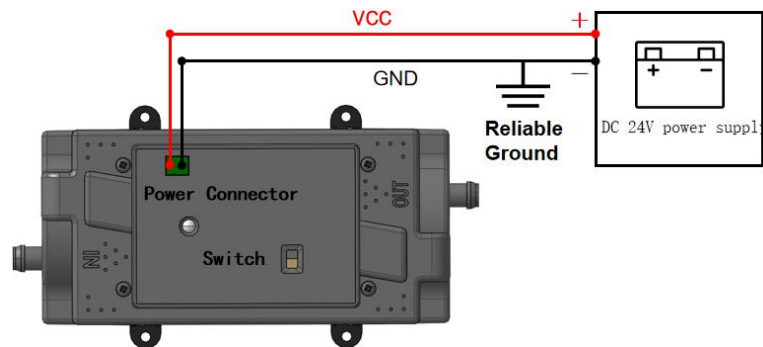

Figure 5-1 Wiring Instructions for Basic Type

Instruction: The red wire of the power connector is connected to the positive pole of the DC 24V power supply, the black wire is connected to the negative pole of the power supply. Control the start and stop of the pump by the toggle switch.

Note: 1. The start and stop of the pump is not allowed by cutting off/connecting the 24V power supply, otherwise it may cause damage to the micro pump motor; if you need to control the start and stop of the micro pump through a signal, please choose a remote control product.

5.2 Remote Control Type

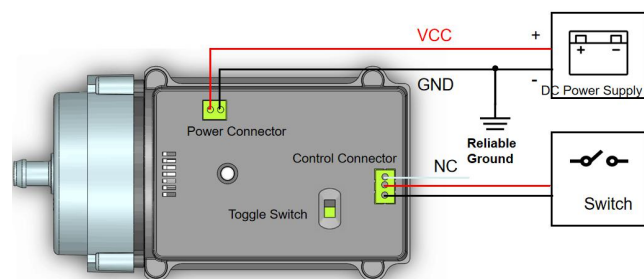

Figure 5-2 Wiring Instructions for Remote Control Type

Instruction: The red wire of the power connector is connected to the positive pole of the 24V DC power supply, and the black wire is connected to the negative pole of the power supply. When using the remote control function, you need to set the toggle switch to the "on" position. The red wire and black wire of the control connector are connected to the hardware switch. If the red wire and the black wire are connected , the pump will stop; if disconnected, the pump will start.

6

Cautions



Please read the instructions in this chapter carefully and follow the instructions strictly before use.

- 1. This product has no waterproof, dust-proof, and explosion-proof functions and cannot be used in flammable and explosive environment!**
- 2. Foreign matter must not fall into the hydraulic connectors, and there should be no solid particles in the medium, otherwise the micro pump will be damaged!**
- 3. When used as a compressor, the inlet of the pump must keep unobstructed, otherwise it will damage the micro pump!**
- 4. When used as a vacuum pump, the outlet of the pump must keep unobstructed, otherwise it will damage the micro pump!**
- 5. When this product is used to transfer harmful medium, it must be double-sealed to ensure personal safety!**
- 6. The matching piping components and containers must have sufficient strength to ensure personal safety!**
- 7. Built-in precision control circuit, need to use high-quality switching power supply or DC stabilized power supply!**
- 8. This series of products are not allowed to be shut down directly by cutting off the 24V power supply. To stop the machine, the user shall perform a soft shutdown through the panel toggle switch or remote control switch before cutting off the power supply, otherwise it may affect the motor life!**

9. If this series of pumps are not used with our matching power supply, it may cause interference to the operation of the pump. Leading the ground wire at the power connector to reliably ground will help improve the reliability of operation!

10. Please operate strictly in accordance with the requirements of this user guide.

7 Dimensions

Overall Dimensions of D60 C61 Basic Type (Unit: mm)

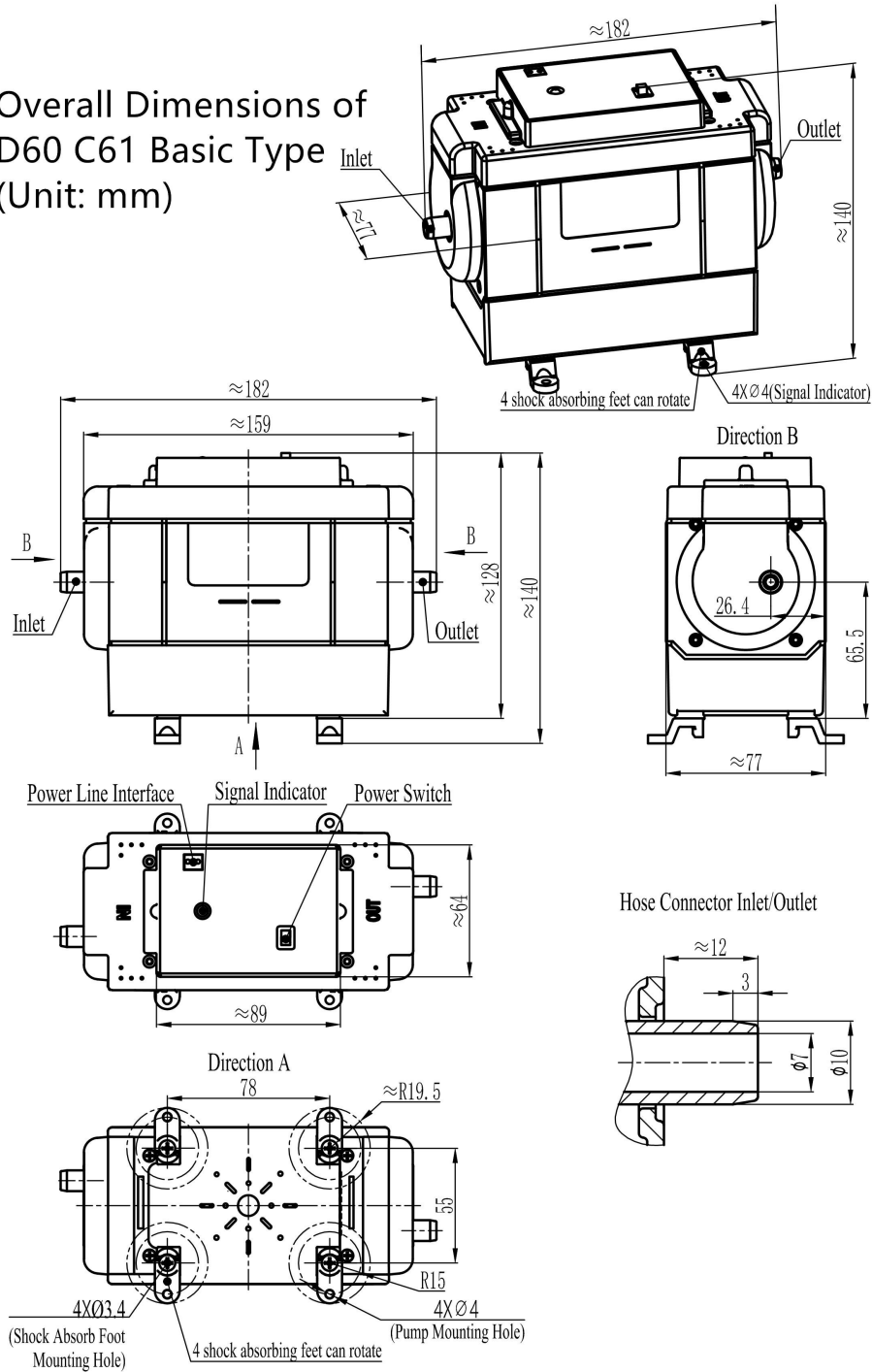

Overall Dimensions of
D60 C61 Remote Control Type
(Unit: mm)

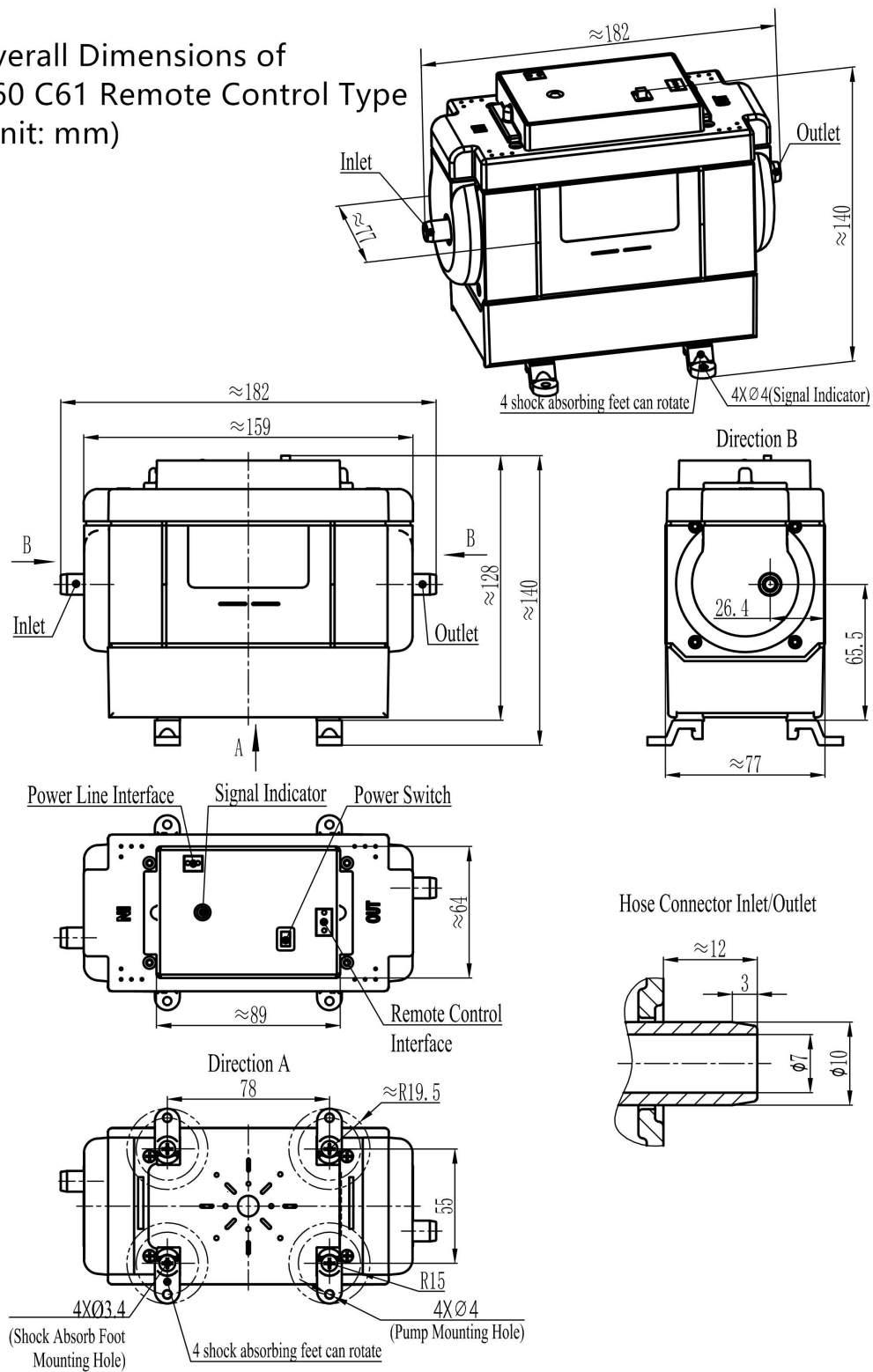

Installation instructions:

1. The screws on the pump cannot be removed, otherwise it will damage the pump;
2. The mounting holes are self-tapping screw holes, not suitable for repeated tightening and disassembly, otherwise the installation will be loose and unreliable.

8 Appearance

D60-Basic Type



D60-Remote Control Type

