

VBY Flow Control Micro Vacuum Pump



Datasheet



Highlights

- Low electromagnetic interference
- Optional nozzle installation direction
- Long service life under max load
- Continuous operation with max load
- Low noise level and vibration
- Driven by BLDC motor
- Industrial-grade reliability
- Good air tightness
- High vacuum
- Compact size

Applications

- Gas sampling
- Medical equipment
- Analytical instruments
- Vacuum suction

12K hours
lifetime test

PERFORMANCE DATA

Model	Voltage (V DC)	Max. Load Current (mA)	Max. Peak Flow rate (L/min)	Max. Average Flow rate (L/min)	Max. Vacuum (-kPa)		
Material Option A	Diaphragm:EPDM Valves:EPDM Pump Head: Fiber reinforced nylon						
VBY7505A	12V	≤500mA	≥5	≥3.5	≥75		
VBY7506A	24V	≤300mA	≥6	≥4.5	≥75		
VBY8009A	24V	≤300mA	≥9	≥5.0	≥80		
Note: The peak flow refers to the flow value measured by the rotameter, and the average flow refers to the flow value measured by the soap film flowmeter							

CONFIGURATION OPTIONS

Material Options

Pump Head Fiber reinforced PA6

Diaphragm EPDM

Valves EPDM

Motor BLDC

Connector Options

PA hose connector in different directions

Function Options

Basic type

RELIABILITY DATA

Models Versions	VBY Series		
	Simplified	Standard	Premium
Fully Loaded Lifetime (hrs)	5000	8000	12000
Unloaded Lifetime (hrs)	8000	12000	18000
Motor Lifetime (hrs)	10000	15000	20000
Test conditions	In a clean and non-corrosive laboratory, the pump is fully loaded (the outlet is blocked, the inlet is directly connected to the atmosphere) or unloaded (the inlet and outlet are directly connected to the atmosphere), and runs continuously around the clock; ambient temperature: 5°C~33 °C, relative humidity: 50%-85%, fluctuates with the climate.		
Working Condition			
Operating temperature	Permissible ambient temperature is 0°C~50°C, it is not suitable to be exposed to the sun, and it should work in a clean and ventilated environment		
Medium	Permissible temperature of the medium is 5°C~50°C, the transferring gas is allowed to be rich in water vapor, but cannot contain solid particles		
Wetted materials	EPDM, fiber reinforced nylon, tolerance to alcohol, acid, alkali, etc. (except strong acid, concentrated acid, lipids, benzene, gasoline, etc.)		

VBY MODEL KEY

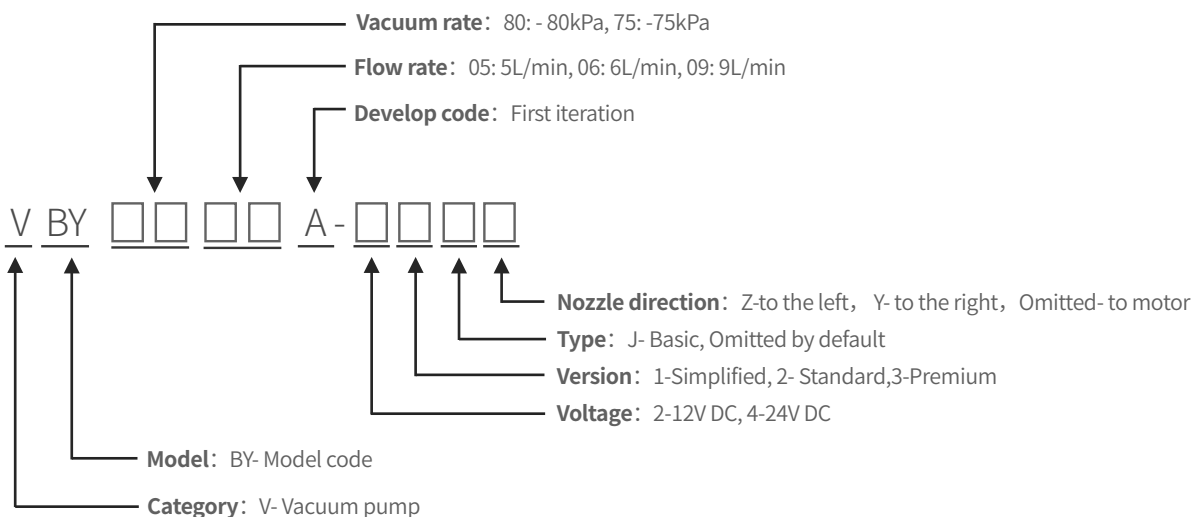

VBY7505A FLOW CURVE

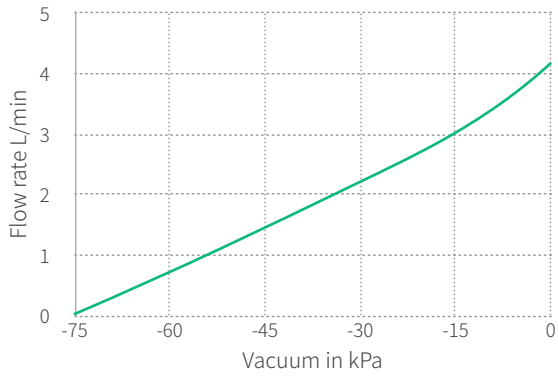

VBY7506A FLOW CURVE

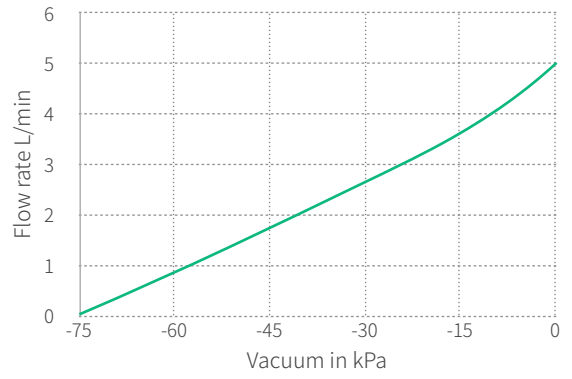

VBY8009A FLOW CURVE

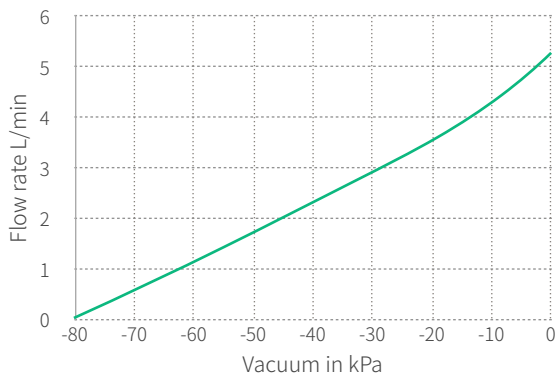

VBY8009A DIMENSIONS

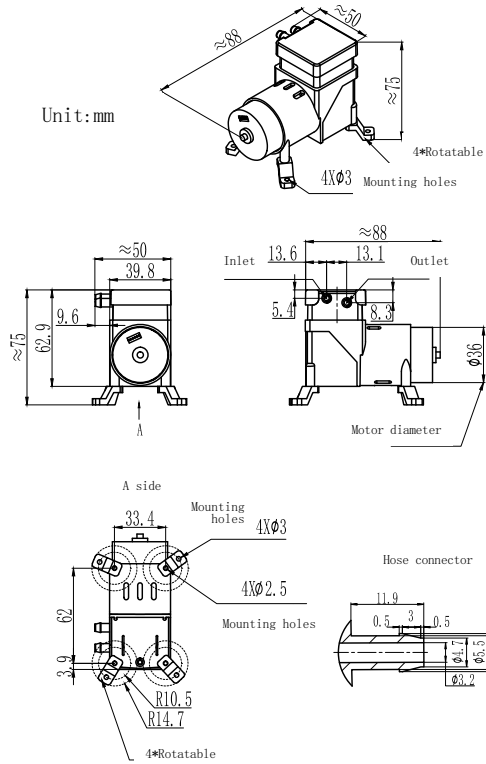

VBY8009A DIMENSIONS

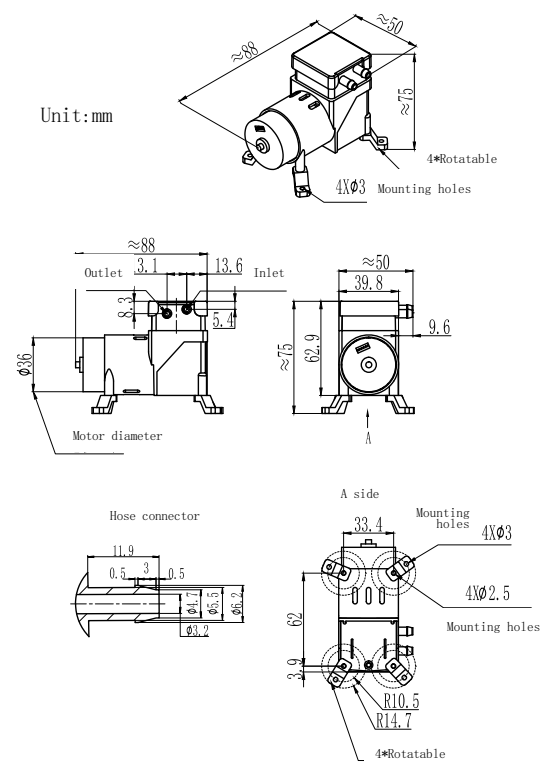

VBY7505A DIMENSIONS

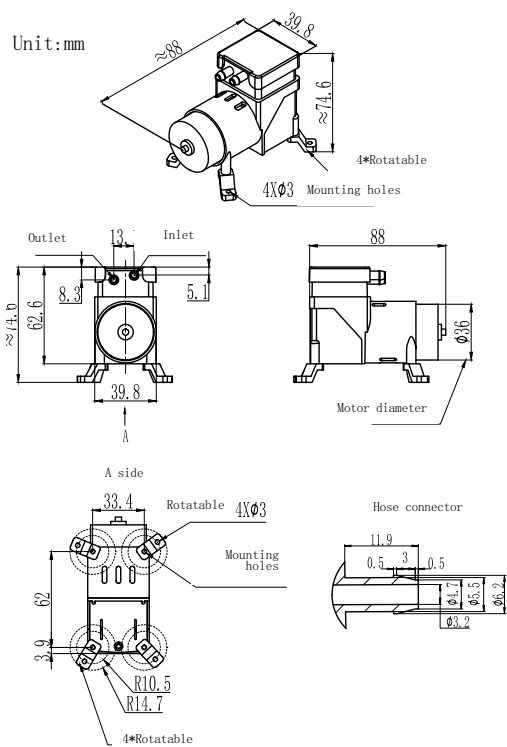

VBY7506A DIMENSIONS

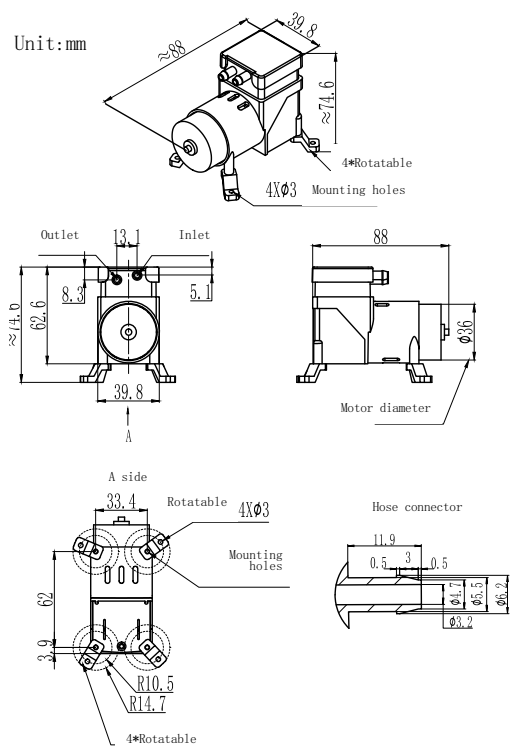

ACCESSORIES		
Descriptions	Illustration	Function
Shock-isolation mounting feet		Reduce the impact of vibration on the equipment during the operation of the pump. This accessory comes with the pump*4
Filter		The 80-mesh filter protect both pumps and other upstream instrumentation and hydraulic circuits against particulate, crystals and fibers . It is recommended to replace it regularly. This accessory comes with the pump*1
Check valve		Enhance the cut-off capability of the gas circuit system to ensure one-way gas flow. This accessory can be purchased on demand
Flow stabilizer		Eliminate and reduce pulsation, make gas output smooth and stable, this accessory can be purchased on demand
Manual control valve		It can be used to manually adjust the gas flow rate, pressure and vacuum. This accessory can be purchased on demand
DC power adapter		220V AC to DC switching power supply, this accessory can be purchased on demand
Silencer		It is used to eliminate and reduce the airflow noise caused by pumping operation, this accessory can be purchased on demand



To be a driving force in innovation of human fluid technology

Create value for customers by offering high quality fluid solutions

This document is for reference only and does not constitute any promise or guarantee. The parameters and experimental data indicated in this document come from Hilintec life and aging laboratory and supplier laboratories. In the actual user system, due to differences in actual usage conditions and experimental conditions, relevant value will change accordingly. Due to product improvement needs, the parameters may be adjusted without notice. Please contact the manufacturer or agent for confirmation before purchasing. The trademarks, pictures, and logos in this document are owned by Chengdu Hailin Technology Co., Ltd. or a third party with legal rights.



www.mini-pump.com