



C30 Vacuum Pump Series

User Guide

Issue 15
Date 2020-06



Copyright © Chengdu Hilin Technology Co., Ltd. 2020. All rights reserved.

No part of this document may be reproduced or transmitted in any form or by any means without prior written consent of Chengdu Hilin Technology Co., Ltd.

Trademarks and Permissions

 is a trademark of Chengdu Hilin Technology Co., Ltd.

All other trademarks and trade names mentioned in this document are the property of their respective holders.

Notice

The purchased products, services and features are stipulated by the contract made between Chengdu Hilin Technology Co., Ltd. and the customer. All or part of the products, services and features described in this document may not be within the purchase scope or the usage scope. Unless otherwise specified in the contract, all statements, information, and recommendations in this document are provided "AS IS" without warranties, guarantees or representations of any kind, either express or implied.

The information in this document is subject to change without notice. Every effort has been made in the preparation of this document to ensure accuracy of the contents, but all statements, information, and recommendations in this document do not constitute a warranty of any kind, express or implied.

Chengdu Hilin Technology Co., Ltd.

Address: No.3663 Section 2 Muhua Road
Shuangliu District
Chengdu Sichuan China 610000

Website: <http://www.hilintec.com>

Tel: +86-28-62567958

About This Document

Purpose

This document is related to the C30 flow control vacuum pump products, which is used to guide relevant technical personnel to initially understand the characteristics of the product.

Intended Audience

This document is intended for technical personnel. You should have a good understanding of your product and have a clear concept of the relevant parameters, specifications, and other information of the applications of the micro pump.

Keyword

LCD touchscreen speed control, frequency speed control, anti-loosening connectors, knob speed control, related parameters, wiring instructions

Change History

The change history accumulates each update of this document. The latest version of the document contains all the previous updates.

Issue	Date	Product Version	Issuer	Modification
10	2019-11	1.0	LWL	Correct overall dimensions
11	2019-12	1.0	XYL	Update current parameters
12	2020-1	1.0	LWL	Correct wiring instruction of top configuration type
13	2020-5	1.0	LWL	Add flow curve, starting current curve, type of connectors
14	2020-5	1.0	LYZ	Correct description of frequency signal speed control
15	2020-6	1.0	LWL	Update description of medium

Contents

About This Document	I
Change History	II
Contents	III
1 Characteristics	1
1.1 Working Status Indicator.....	1
1.2 Brush-less DC Motors.....	1
1.3 Protections.....	1
1.4 Modular Pneumatic Connectors.....	2
2 Special Functions	3
2.1 Speed Control Function.....	3
2.2 Working Status Indication and Warning.....	3
2.3 State Memory Function.....	4
3 Technical Specifications	5
3.1 Key Specifications.....	5
3.2 Description of Types.....	6
3.3 List of Models Combination for Sale.....	6
3.4 Description of Versions.....	7
3.5 Options of Modular Pneumatic Connectors.....	8
3.6 Life-time Test Conditions.....	8
3.7 Working Conditions.....	8
3.8 Materials.....	9
3.9 Vacuum Degree-Flow Curve.....	10
3.10 Starting Current Curve.....	13
4 Product Model Description	16
4.1 Brief Description of Model Naming.....	16

5 Electrical Connection.....	17
5.1 Basic Type.....	17
5.2 Knob Speed Control Type.....	18
5.3 Frequency Speed Control Type.....	20
5.4 Top Configuration Type.....	23
5.5 Alarms and Troubleshooting.....	26
6 Cautions.....	27
7 Dimensions.....	28
8 Appearance.....	31
C30 Top Configuration Type.....	31
C30 Basic Type.....	33

1

Characteristics



1.1 Working Status Indicator

Only the knob speed control type and frequency speed control type are equipped with working status indicator lights, which can directly feed back the working status of the pump. The top configuration type is equipped with an LCD touch screen that can display working status and fault codes.

1.2 Brush-less DC Motors

This model is driven by brush-less motor which has the advantages of long service life, low interference and high reliability.

1.3 Protections

Equipped with overheating protection, overload protection, power supply under-voltage and over-voltage protection and reverse connection protection function, which to the greatest extent prevents accidental damage to the pump.

1.4 Modular Pneumatic Connectors

This series of pumps has Rc1/8 internal thread interface, which can be installed with stainless steel push-in connectors (6mm and 8mm inner diameter), reinforced nylon hose connector, stainless steel hose connectors and PP hose connectors. This product is equipped with reinforced nylon hose connectors as standard. The standard reinforced nylon hose connector is recommended to match 4*8 silicone tube and the optional plastic and stainless steel hose connectors are recommended to match with 7*13 silicone hose. The size of the tube can be appropriately changed according to the softness and hardness of the hose. There are two options of stainless steel push-in connectors for matching with 6*8 or 4*6mm hard tubes. The user can select the corresponding pneumatic connectors when ordering according to the pipeline situation. For ordering options, see section 3.5.

2 Special Functions

2.1 Speed Control Function

The flow rate of the pump can be changed by adjusting the motor speed. The top configuration type is equipped with an LCD touch screen and speed control signal interface, which can be used to start and stop and control the motor speed through the LCD touch screen, and also through frequency signals. Knob speed control type models have an external speed control knob, which can control the speed, start and stop of the pump. Frequency speed control type models can be controlled by user inputting frequency signal. Please refer to Chapter 5 Electrical Connection for specific usage of different speed adjustment methods.

2.2 Working Status Indication and Warning

1.The knob speed control type and frequency speed control type are equipped with working status indicator lights. Users can understand the working status of the equipment through the color change of the indicator lights

a. When the green light is constantly on, it means the power supply is normal and the pump is not working;

b.When the green light flashes, it means the pump is working normally;

c.When the indicator light remains red, it means that the power supply voltage is too high or too low. If the voltage is correct and the red light is constantly on, it means the pump is working abnormally;

d.When the positive and negative poles are reversed, the indicator light is off, the pump does not work, but it will not damage the pump.

2.The top configuration type is equipped with an LCD touch screen.Alarm codes will be displayed when different faults occur, which makes fault handling more convenient. (The figure below is for illustration only, please refer to Chapter 5 Alarms and Troubleshooting for details.)



2.3 State Memory Function

When the pump is stopped due to abnormal power failure, the pump will continue to run according to the state and speed of the last power-off when the power supply is recovered. When using the knob or touch switch to start the pump, the pump will continue to run at the speed before the last shutdown. (**Note:** This function is only valid on the frequency speed control type, knob speed control type and top configuration type.)

3 Technical Specifications

3.1 Key Specifications

Model	Rated Voltage (VDC)	Load Current (mA)	Flow (L/min)		Relative Vacuum (-kPa)
			Peak Flow	Average Flow	
C30L	24	≤300mA	≥6.0	≥4.1	≥48
C30M	24	≤280mA	≥5.0	≥3.5	≥43
C30S	24	≤250mA	≥5.0	≥3.3	≥41
C30L	12	≤380mA	≥6.0	≥3.5	≥48
C30M	12	≤350mA	≥5.0	≥3.0	≥43
C30S	12	≤350mA	≥4.0	≥2.5	≥41

- Note:**
- 1.The input voltage requires $24V \pm 10\%$ or $12V \pm 10\%$.
 - 2.Unless otherwise specified, the technical parameters are measured under the conditions of temperature 25°C and standard atmospheric pressure of 101kPa. For products with other parameters and specifications, you can contact us to customize.
 - 3.The parameters in the table are measured at the maximum speed of the motor. When the motor speed changes, the pressure/vacuum level is basically unchanged.
 - 4.The above parameters are measured under the configuration of standard stainless steel hose connectors. If other types of connectors are configured, the parameters may change slightly.
 - 5.The peak flow rate in the table refers to the flow value measured with a rotameter, and the average flow rate is measured with a soap film flow-meter.

3.2 Description of Types

Types	Function and Configurations
Basic Type	Equipped with brushless DC motor, long service life, low electromagnetic interference, and non-adjustable motor speed.
Knob Speed Control Type	Equipped with working status indicator and speed control knob switch, through the knob to adjust the speed, start and stop of the pump.
Frequency Speed Control Type	Equipped with working status indicator, equipped with a signal port to adjust the speed, start and stop through the input frequency signal.
Top configuration Type	Not only equipped with an LCD touch screen to control motor speed and display fault code, but also equipped with speed regulation and feedback signal port.

3.3 List of Models Combination for Sale

Version Type	Simplified Version	Standard Version	Premium Version
Basic Type	√	Customizable	Customizable
Frequency Speed Control Type		√	√
Knob Speed Control Type		√	√
Top Configuration Type			√

Note: √ in the above table means that there is a corresponding product for sale, unchecked means that there is no corresponding product. (The above table does not include customized products)

3.4 Description of Versions

Version Performance	Simplified Version	Standard Version	Premium Version
Life-time	≥2500h	≥6000h	≥10000h
Reliability	★	★★★★	★★★★★★
Parameter consistency	★	★★	★★★
EMC	★	★★	★★★
Ambient temperature	0~40℃	0~50℃	0~50℃

- Note:** 1. The more ★, the better performance of this item.
2. The life-time of the standard version and premium version is still under test, the above is expected value.

3.5 Options of Modular Pneumatic Connectors

Connector Option	Material	Recommended Hose/Tube
Default hose connector	reinforced nylon	Silicone hose with inner diameter 4mm
plastic hose connector	PP	Silicone hose with inner diameter 6~7mm
Stainless steel hose connector	Stainless steel	Silicone hose with inner diameter 7~8mm
PC6 push-in connector	Stainless steel	6mm outer diameter hard tube
PC8 push-in connector	Stainless steel	8mm outer diameter hard tube
Nylon Rc1/8 internal thread	reinforced nylon	Install connectors above or other kind of connectors

Note: The products are shipped with reinforced nylon hose connectors by default. If you need to configure other types of connectors, please specify when ordering.

3.6 Life-time Test Conditions

In a clean, non-corrosive laboratory, the pump carries a full load (the inlet is blocked and the outlet directly connected to the atmosphere), and operates continuously around the clock. The ambient temperature is 5°C ~ 33°C, fluctuates with the climate; the relative humidity is 30% ~ 85%, which fluctuates with the climate.

3.7 Working Conditions

1. Environment: Permissible ambient temperature range of the simplified version products is 0 °C ~ 40 °C , and the permissible

ambient temperature of the standard and premium versions is $0^{\circ}\text{C} \sim 50^{\circ}\text{C}$. The permissible relative humidity of all pumps in this series is $\leq 90\%$, no condensation. The pump should not be exposed to the sun, and should work in a clean and ventilated environment.

2. Medium: Permissible gaseous media temperature range is $0^{\circ}\text{C} \sim 50^{\circ}\text{C}$. The medium is allowed to be rich in water vapor, but cannot contain particles or oil mist.

3. Load: The inlet can be operated at full load (i.e. completely blocked the inlet), but the applied load cannot exceed the maximum vacuum of the pump; the outlet must be unobstructed.

Note 1: Customers who have special requirements for medium temperature can customize high-temperature medium models. The customized high-temperature models are only available in premium versions, such as C30L-43D-GJ (the premium version equipped with a high-temperature medium feature, which allows gaseous medium temperature range of $0^{\circ}\text{C} \sim 100^{\circ}\text{C}$)

Note 2: The inlet of the micro vacuum pump can carry a large load or even being completely blocked is permissible operation. The outlet of the pump must be unobstructed, and there must be no damping elements in the exhaust line!

3.8 Materials

1. The materials of the wetted parts: reinforced nylon and EPDM rubber, stainless steel. Please check the tolerance of the medium according to the wetted material. If you adopt push-in connectors and stainless hose connectors, the material of the wetted parts is stainless steel. For special needs, you can customize or change the material of pneumatic connectors.

2. The material of the pump body is fiber reinforced nylon, and the material of the shock absorb foot is PVC.

3.9 Vacuum Degree-Flow Curve

There are individual differences between different micro pumps, so this curve is a statistical value, only as a technical reference for users to confirm the working point. The "flow" mentioned in this section refers to the "average flow".

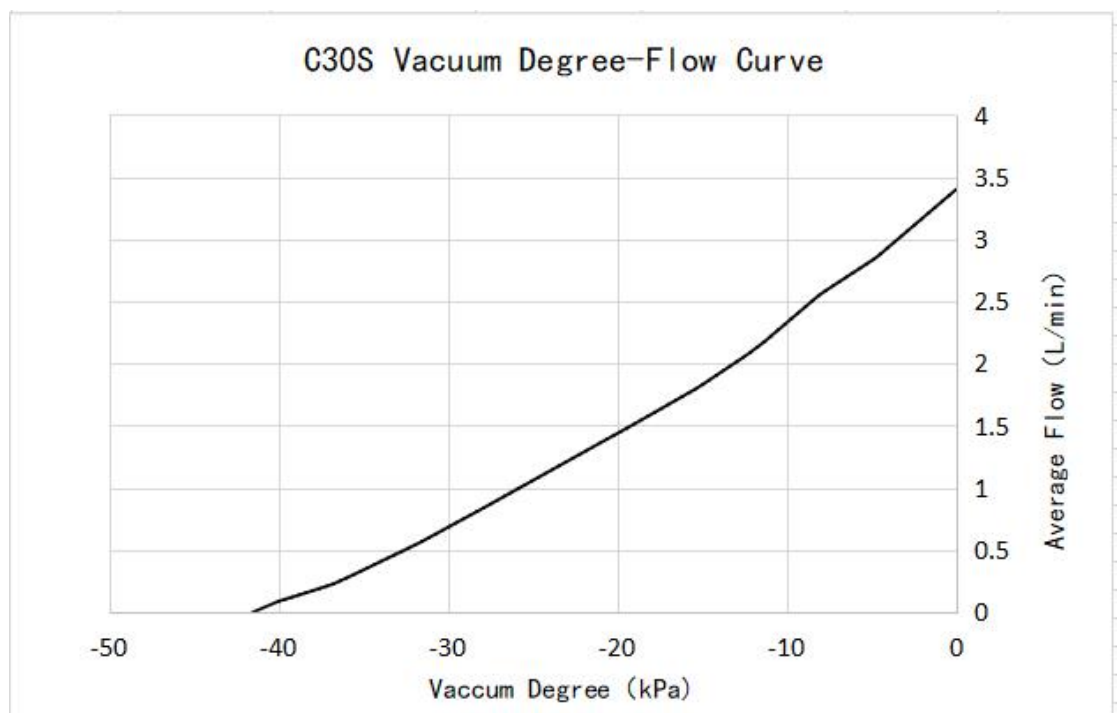
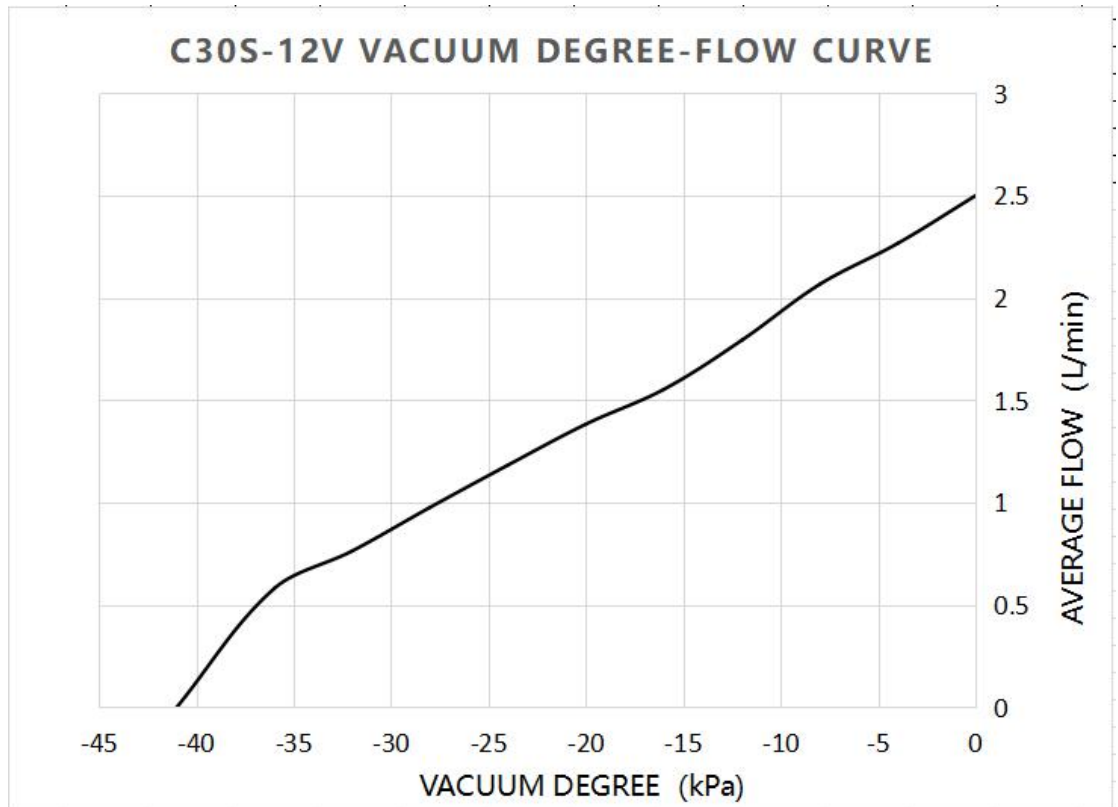

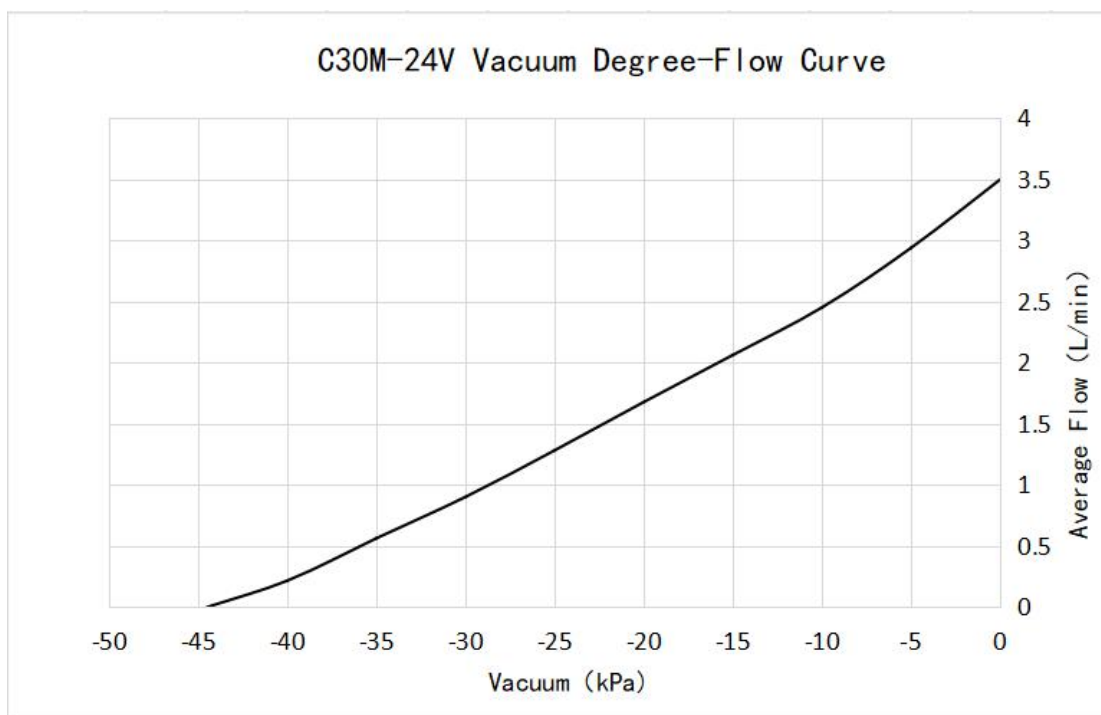
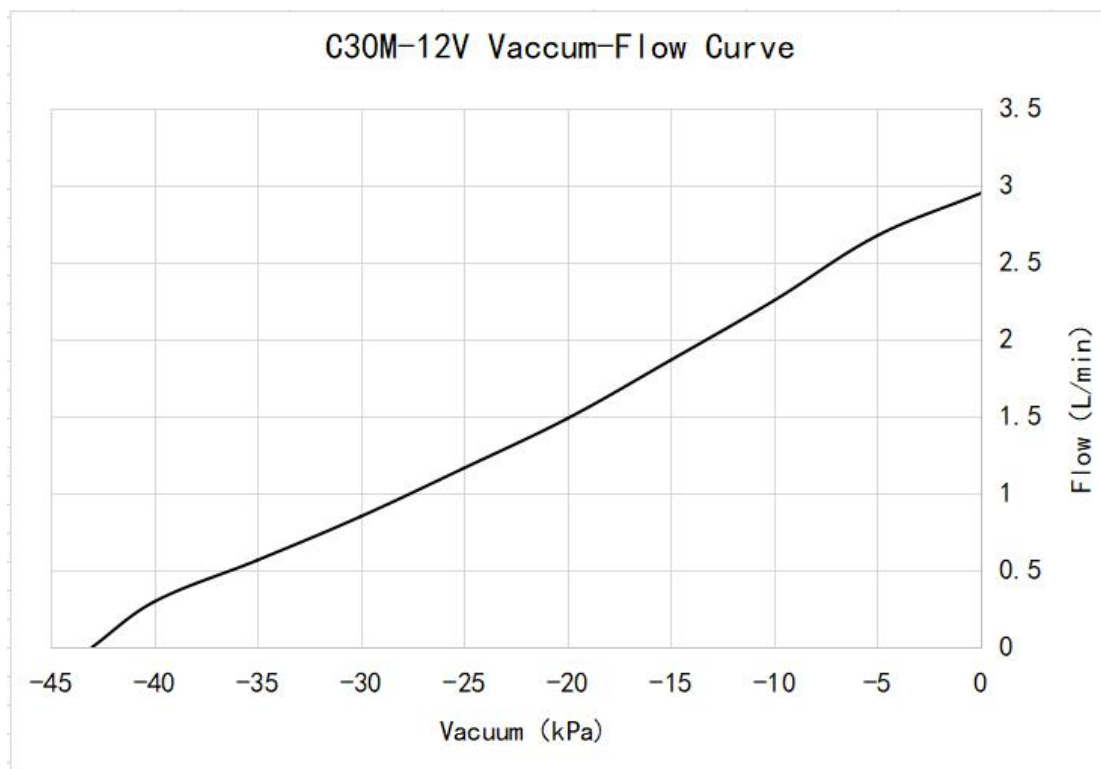

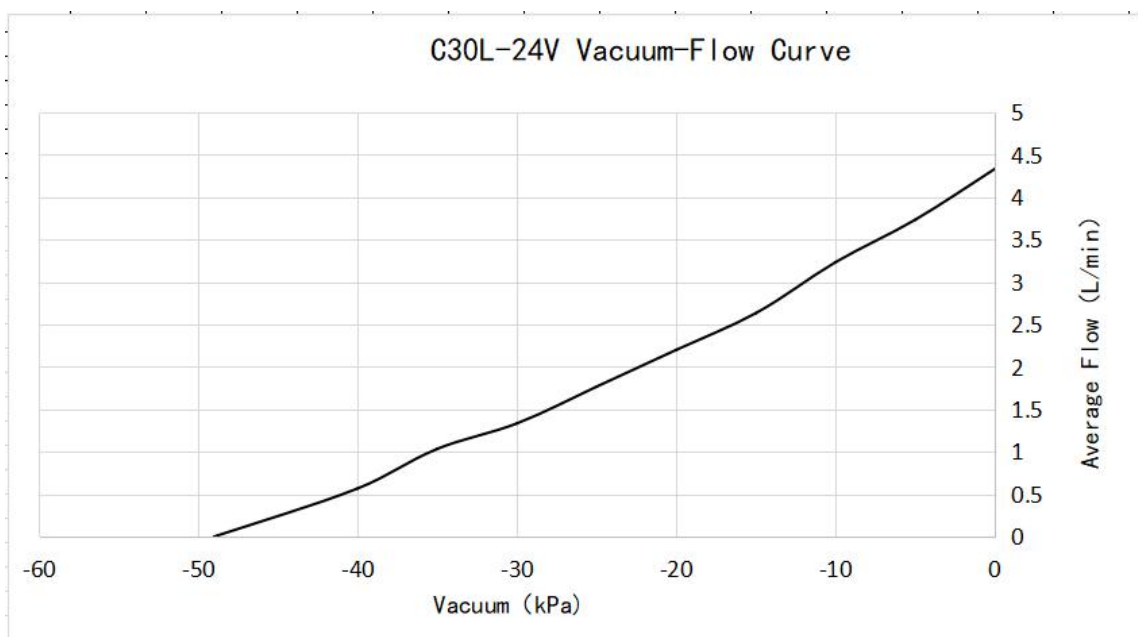
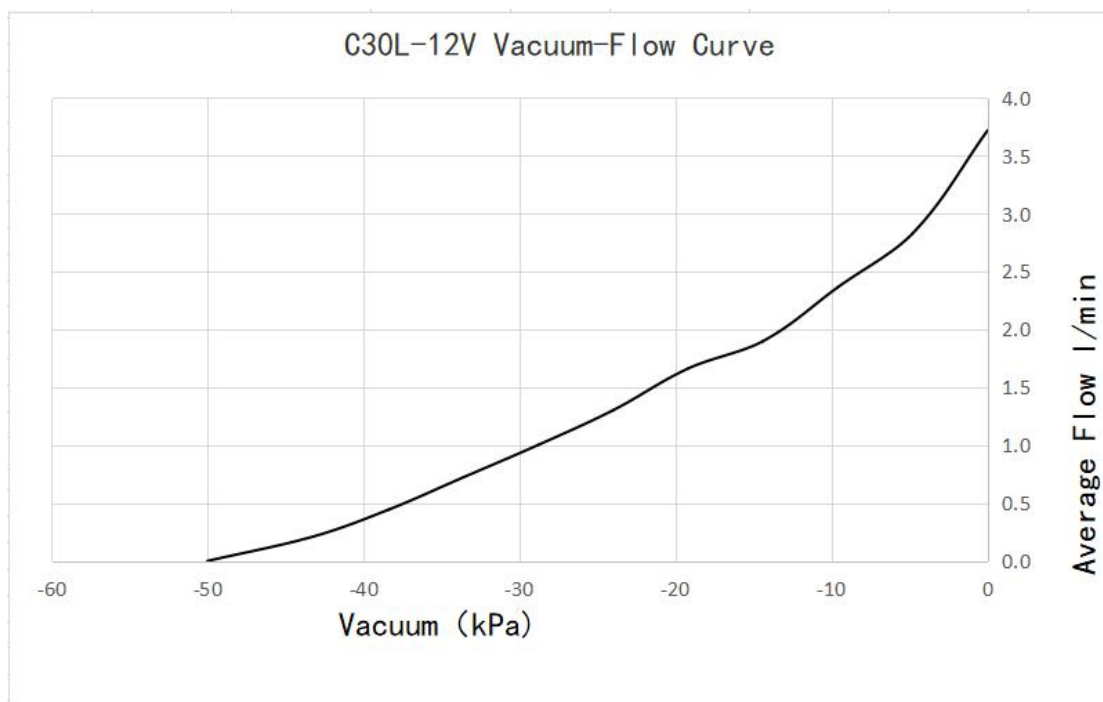

3. 10 Starting Current Curve

The starting current curve is measured under the working condition that the inlet and outlet are directly connected to the atmosphere, and there are certain individual differences between different micro pumps. This curve is a statistical value, which is only used as a technical reference when users determine the power supply system, and is not for acceptance data.

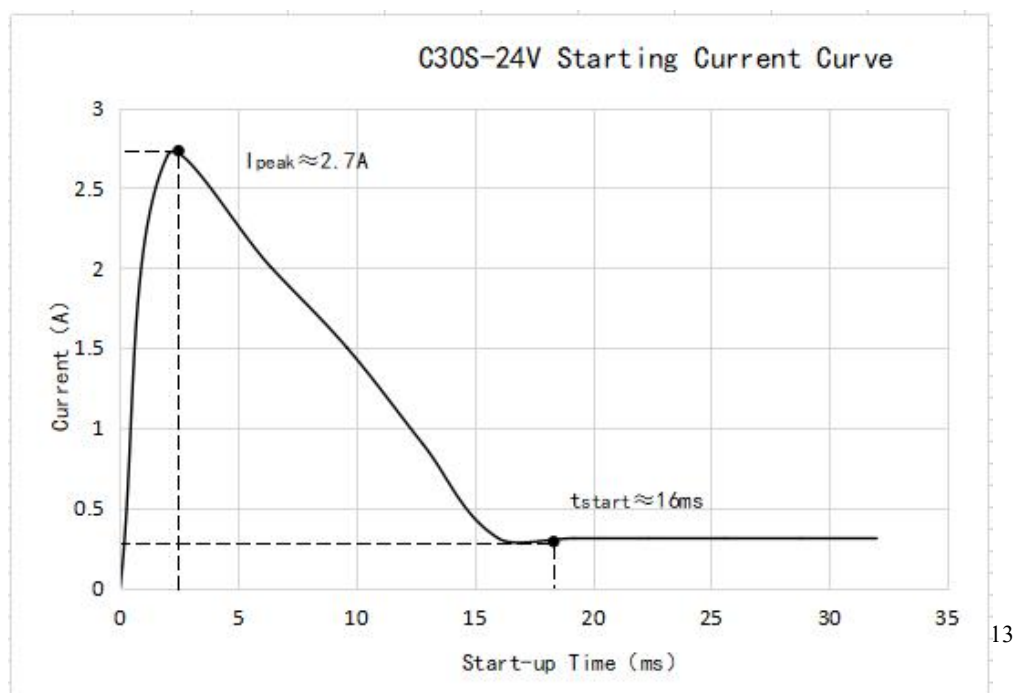
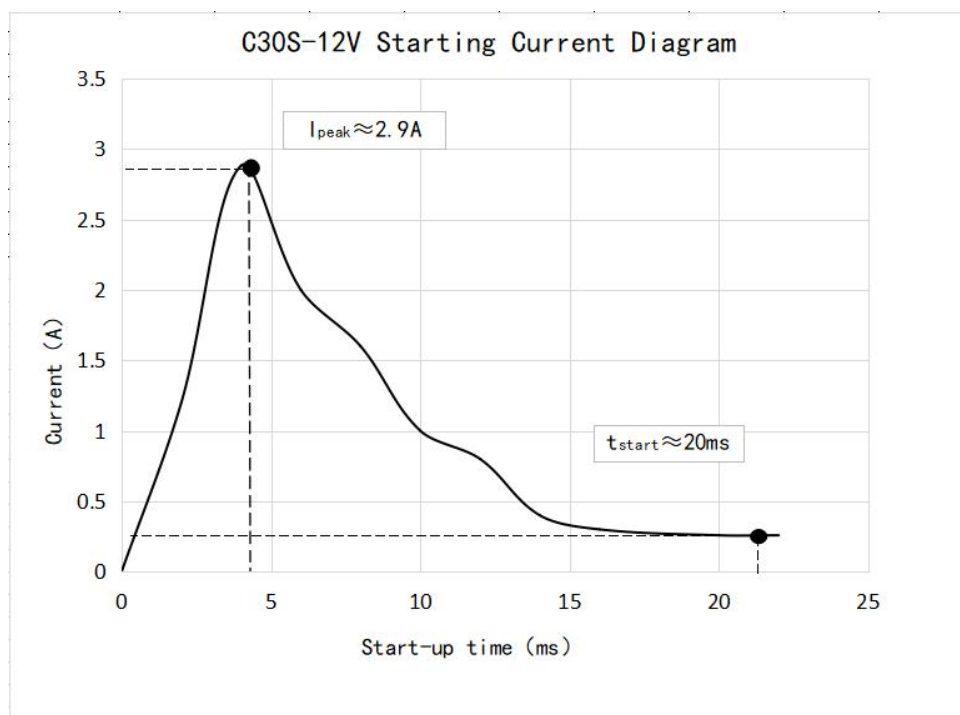

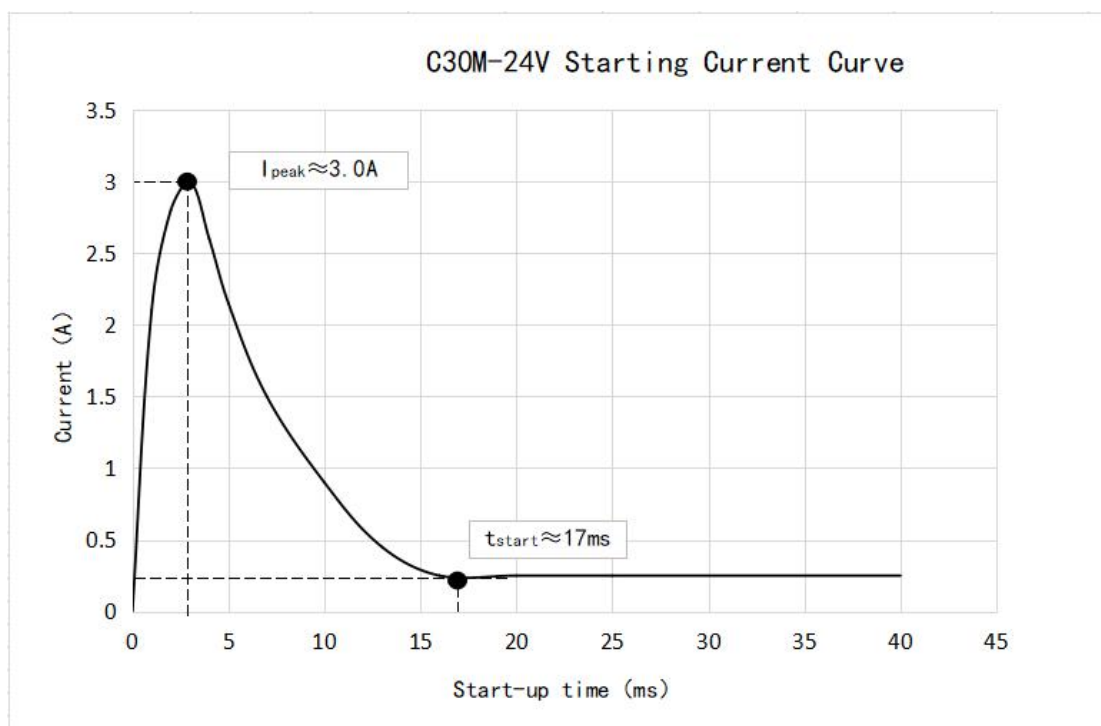
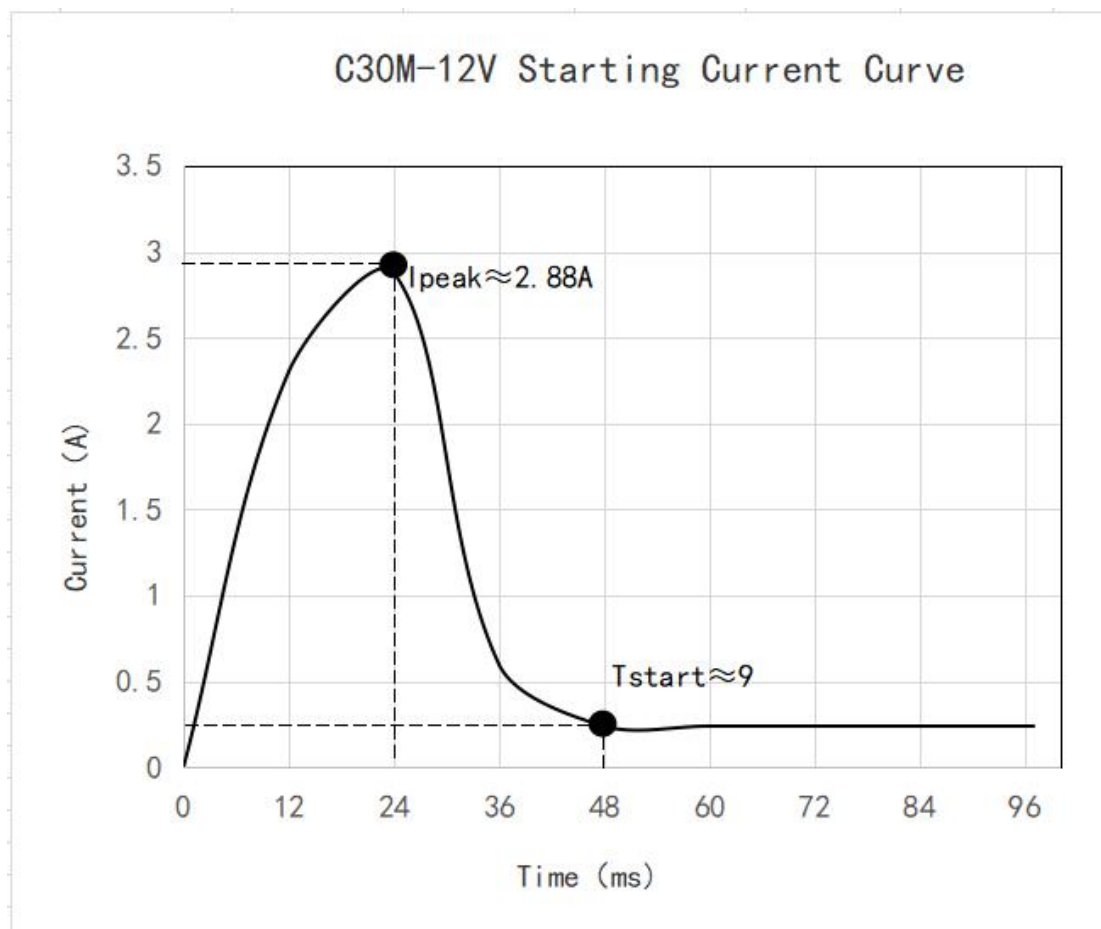

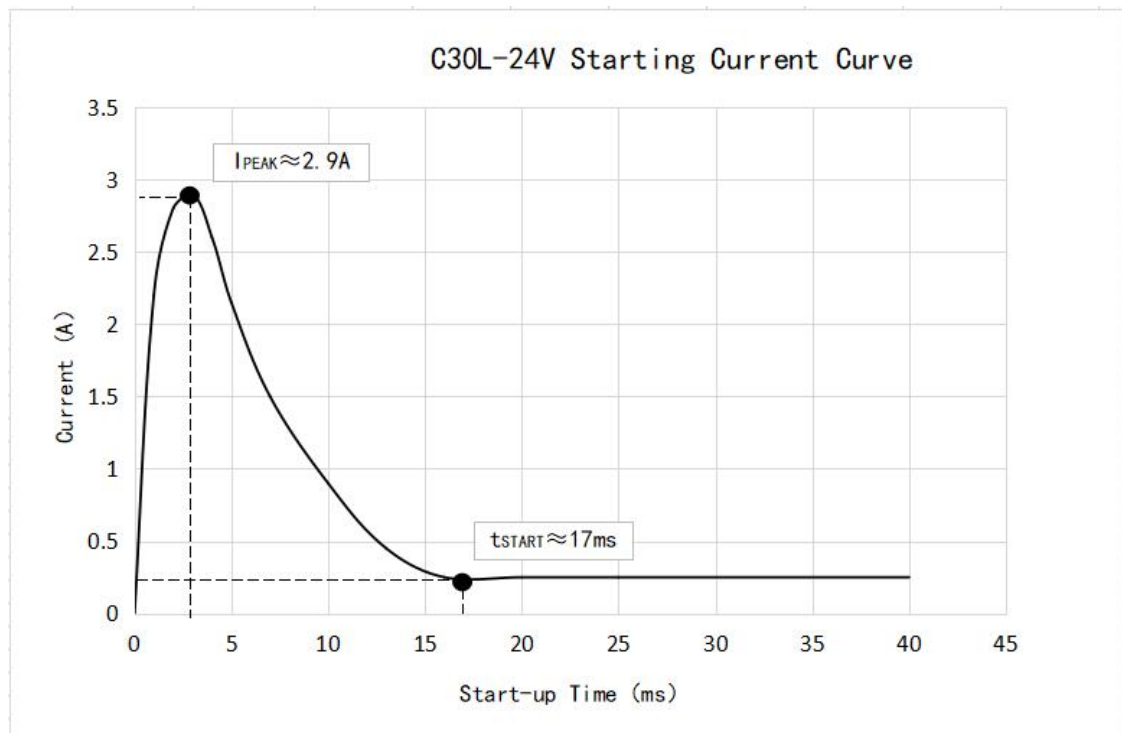
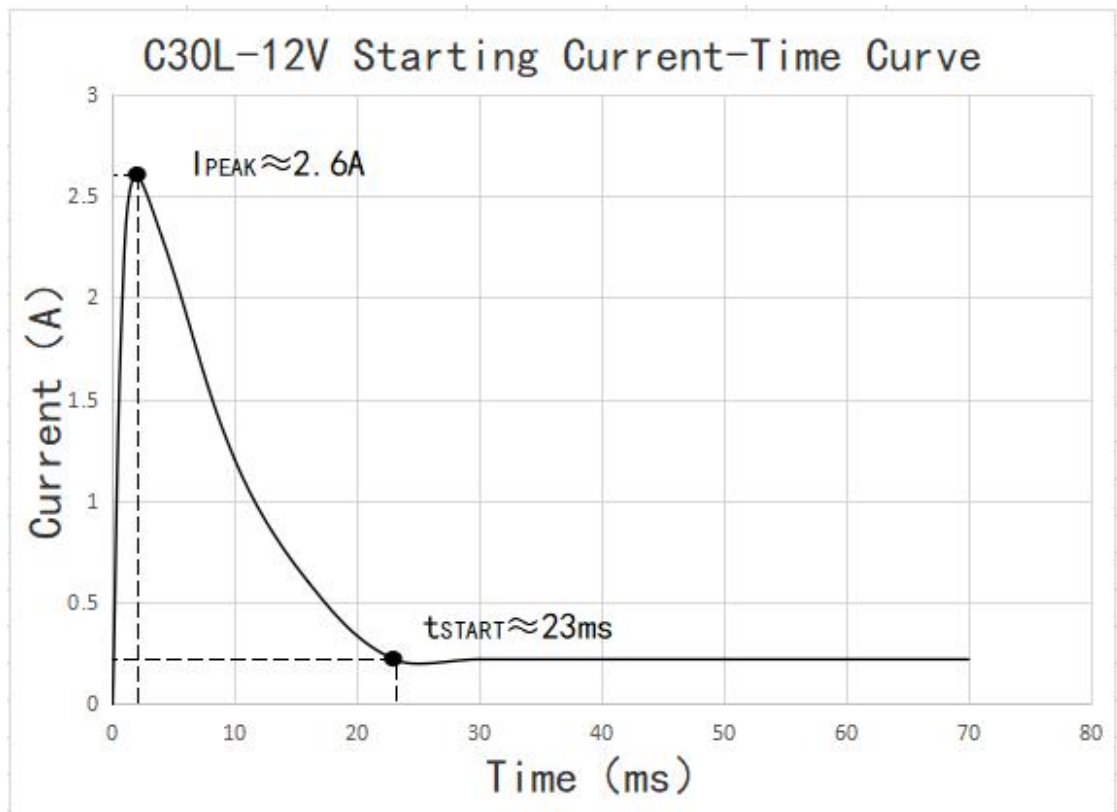

4 Product Model Description

4.1 Brief Description of Model Naming

This series of pumps are divided into four types according to the selected speed control mode: basic type, knob speed control type, frequency speed control type and top configuration type.

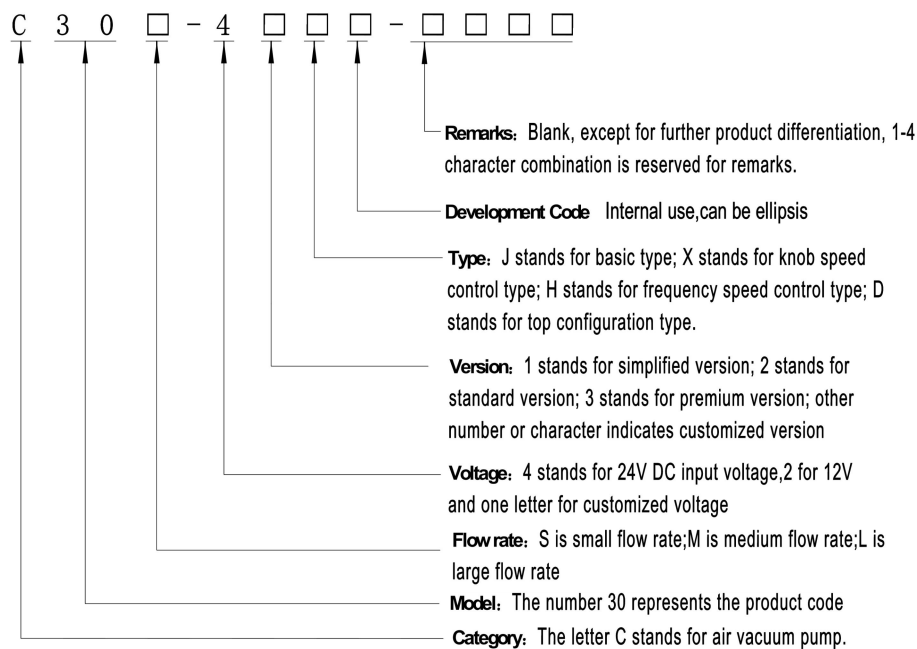

Note: If the remarks starts with a letter, it means a special custom function. For example, letter "GJ" means customized high-temperature medium function, and "GH", means customized high-temperature environment function. If it starts with a number, it means other information.

Example 1: C30-21X (C30 pump, 12V voltage knob speed control simplified version)

Example 2: C30-23D-GJ (C30 pump, 12V voltage top configuration type premium version, customized high temperature medium function)

5 Electrical Connection

5.1 Basic Type

Wire	Input	Definition	Explanation
1 Red	VCC	24V or 12V power input	Rated voltage 24V±10% Or 12V±10%
2 Black	GND	Power Ground	Connect to the negative pole of the DC power

Table 5-1 Wiring Instructions for Basic Type

Note: This type does not have a speed control function. Please connect the wiring strictly according to the instructions in the table above, otherwise it will damage the motor.

The user must ensure the input voltage is 24V before wiring. The wrong input voltage will cause damage to the product and is not covered by the warranty.

5.2 Knob Speed Control Type

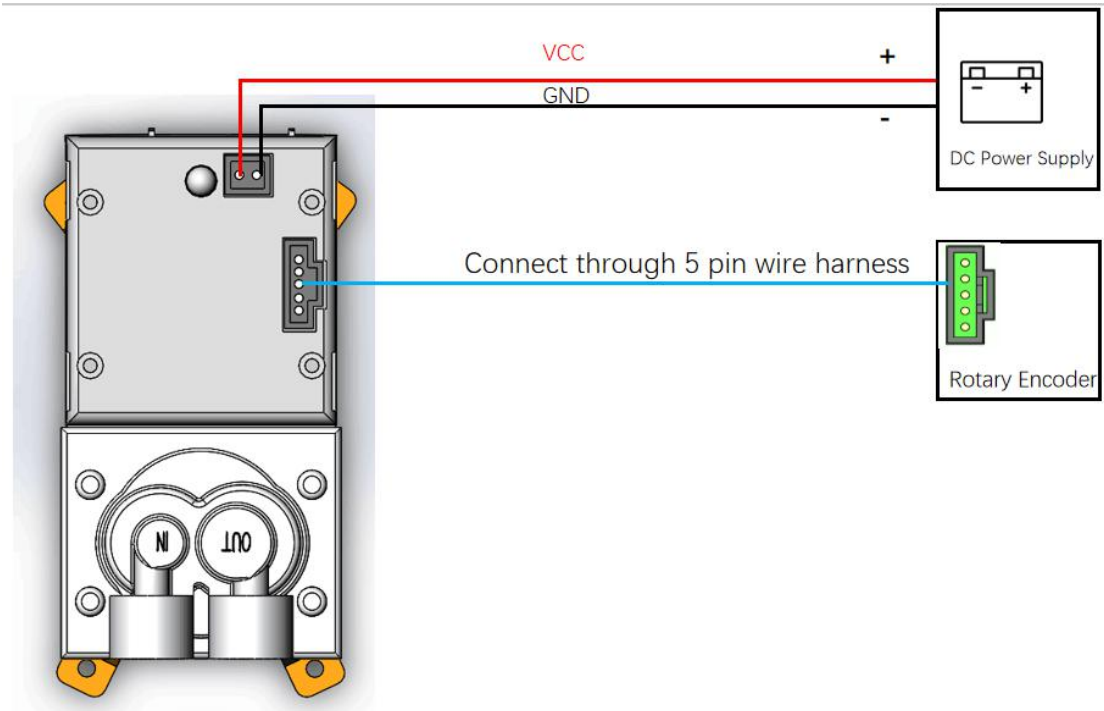

Figure 5-1 Wiring Diagram for Knob Speed Control Type

Note: The wire color in the above figure may be different from the actual wire color, please connect according to the above figure.

The red wire of the power connector is connected to the positive pole of the DC power supply, the black wire is connected to the negative pole of the power supply, and the speed regulation connector is connected to the knob circuit board through the wiring harness. This pump will be equipped with a speed control knob switch (rotary encoder). Rotate the knob on the encoder clockwise to increase the speed. When it reaches the maximum speed, continue to rotate the knob clockwise, it will remain the maximum value. Rotate the knob counterclockwise to decrease the speed. When it reaches the minimum speed, continue to rotate counterclockwise, it will maintain the minimum flow. Press the knob to control the start and stop of the pump. The pump also has a state memory function. When the pump is started, it will run at the speed before the last stop.

Connector	Wire	Input	Definition	Explanation
5Pin Connector	1-5	Knob signal	Knob speed control switch connector	Connect to the knob speed control switch through the 5Pin harness
2Pin Connector	1	VCC	24V or 12V power input	The rated voltage depends on the voltage: 24V±10% or 12V±10%
	2	GND	DC power ground	connect to the negative pole of the DC power supply

Table5-2 I/O Interface Definition of Knob Speed Control Type

Attachment: Installation instructions for speed control knob switch

(1) Nut installation: first make a hole with a diameter of about 7mm on the mounting plate, then unscrew the nut on the encoder and remove the gasket, insert the knob of the encoder into the opened hole on the mounting plate, and finally install the gasket and screw back the nut.

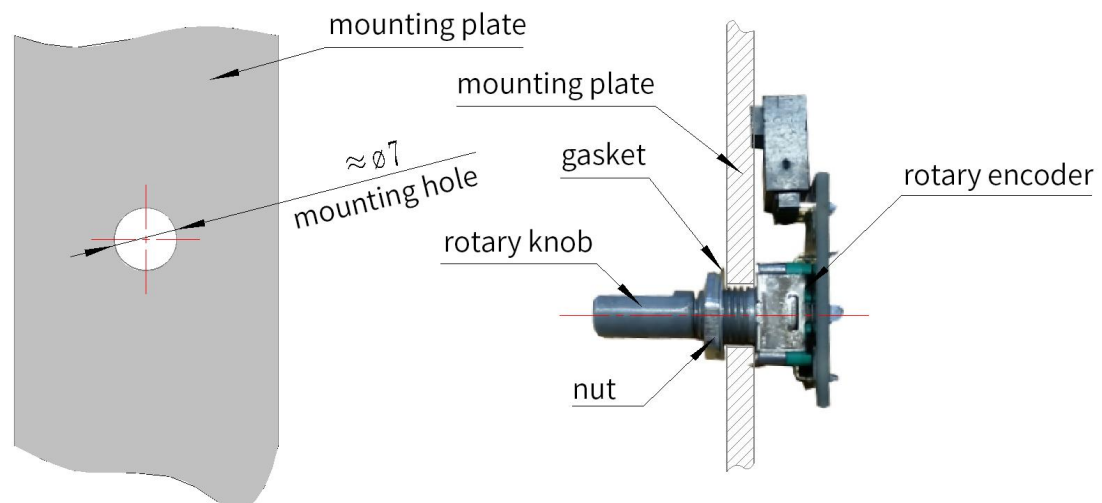

Figure 5-2 Nut Installation

(2)Screw installation: Use two M3 screws to pass through the screw holes and washers of the speed control knob switch, and then fix them to the mounting plate.

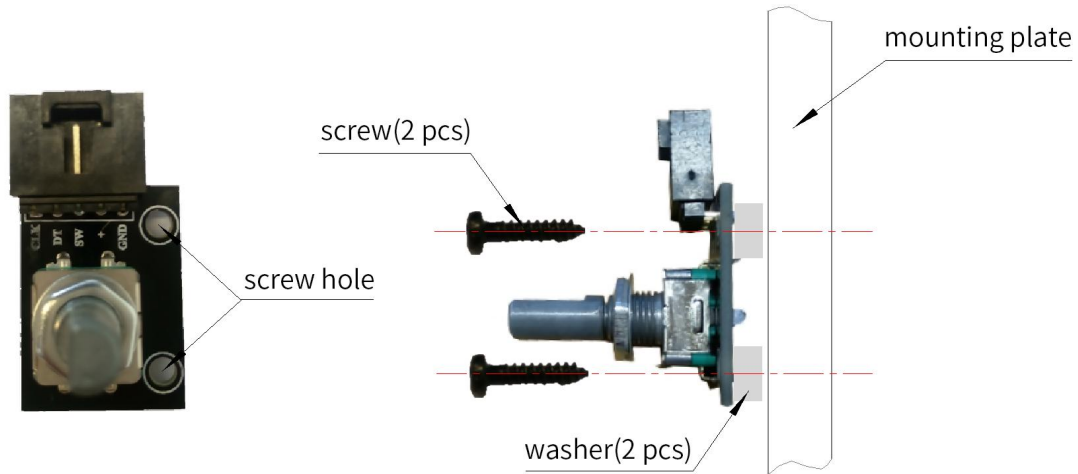

Figure 5-3 Screw Installation

Note: In order to avoid welding protrusions on the back of the speed control knob switch to affect the installation, we have attached two $\Phi 3^* \Phi 7^*3$ insulating washers in the installation accessories. Two M3 screws are usually used for the screws, which need to be prepared by the customer.

5.3 Frequency Speed Control Type

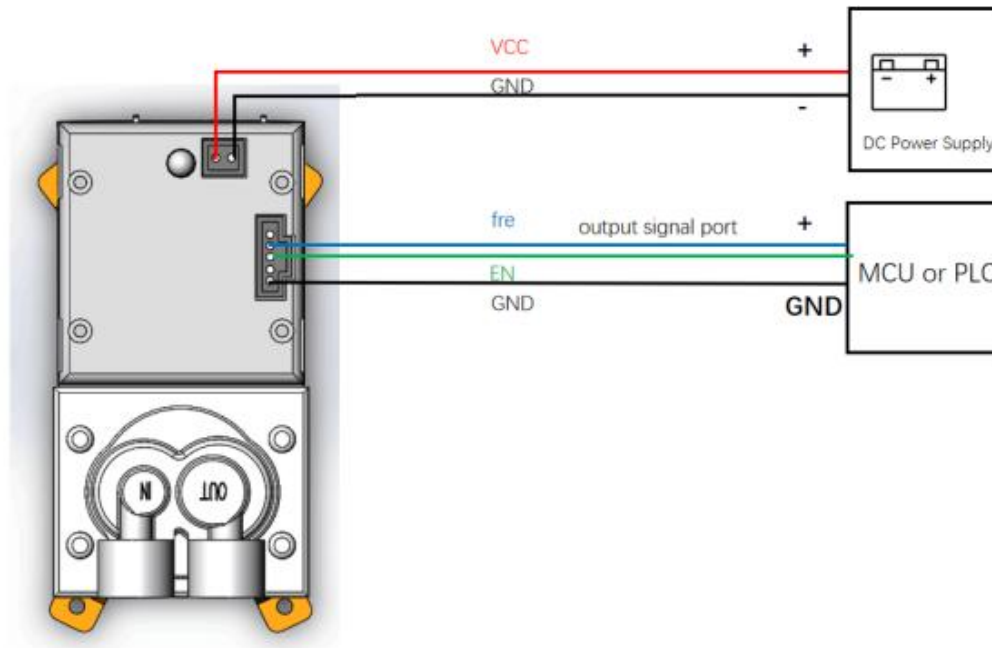

Figure 5-4 Wiring Diagram of Frequency Speed Control Type

Note: The wire color in the above figure may be different from the actual wire color, please connect according to the above diagram.

The red wire of the 2pin power connector is connected to the positive pole of the DC power supply, and the black wire is connected to the negative pole of the power supply as shown in the above diagram. The pin sequence from top to bottom of the speed regulation connector is the same as the actual product as shown in the diagram above. The black wire of pin 5 (GND) is connected to the ground of the MCU or PLC. The pin-3 (En) green wire is connected to the low level of the MCU or PLC, and the pin-2 (Fre) blue wire is connected to the frequency signal output port of the MCU or PLC.

Connector	Wire	Input	Definition	Explanation
5Pin	1	NC	Not connected	

Connector	2	Fre	<p>Frequency speed control signal</p> <p>$0V \leq \text{low level} \leq 0.8V$</p> <p>$3.3V \leq \text{high level} \leq 5V$</p> <p>Note: Input high level $> 3.3V$, the maximum input voltage should not exceed 5V, otherwise it may cause permanent damage to the micro</p>	<p>Input the square wave, recommended amplitude value 5V, duty cycle 50% and the DC bias voltage 2.5V.</p> <p>The signal frequency range 700hz-3100Hz corresponds to motor speed of 700-3100rpm, when $100 < \text{frequency} < 700\text{Hz}$, it runs at the minimum speed, when $\text{frequency} > 3100\text{Hz}$, it runs at the maximum motor speed, and when the $\text{frequency} \leq 100\text{Hz}$, the pump stops running.</p>
	3	EN	<p>Enable signal</p> <p>$0V \leq V_{IL} < 0.8V$</p> <p>$3.3V \leq V_{IH} \leq 5V$</p>	<p>Enable signal, low level is effective to enter the speed control mode, high level or floating means running at the last recorded speed.</p>
	4	NC	Not connected	
	5	GND	Ground	Power and signal ground
2Pin Connector	1	VCC	24V DC power supply	Rated voltage $24V \pm 10\%$ or $12V \pm 10\%$
	2	GND	Power ground	Connect to the negative pole of power supply

Table 5-3 Interface Definition of Frequency Speed Control Type

5.4 Top Configuration Type

The top configuration type is not only equipped with the LCD touch screen speed control and fault display function, but also equipped with a control signal port, as well as frequency speed control function and speed feedback function. The following is a description of the signals corresponding to the wire terminal of the top configuration type.

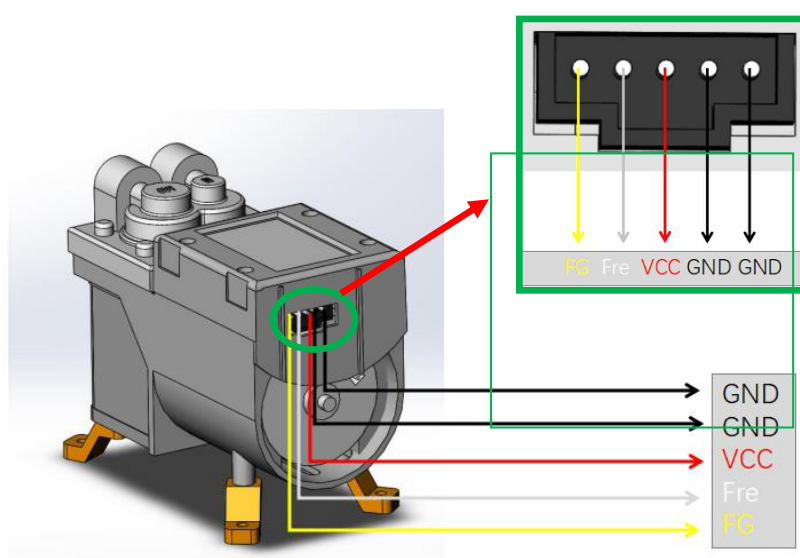

Figure 5-5 Description of Wire Terminal Signal of Top Configuration Type

Wire	Input	Definition	Explanation
1 Yellow	Fg	Speed feedback signal $3.3V \leq \text{high level} \leq 5V$ $1 \leq \text{low level} < 0.8V$	The rotation speed of the motor can be obtained through the feedback signal of Fg, and the 6 square waves fed back means one rotation of the motor.
2 White	Fre	Frequency speed control signal $3.3V \leq \text{high level} \leq 5V$ $0 \leq \text{low level} < 0.8V$	Input the square wave, recommended amplitude value is 5V, duty cycle 50% and the DC bias voltage 2.5V. The signal frequency range 700hz-3100Hz corresponds to motor speed of 700-3100rpm, when $100 < \text{frequency} < 700\text{Hz}$, it runs at the minimum speed, when $\text{frequency} > 3100\text{Hz}$, it runs at the maximum motor speed, when $\text{frequency} \leq 100\text{Hz}$, the pump stops running.

3Red	VCC	24V or 12V power supply	Rated voltage 24V ± 10% or 12V ± 10%
4Black	GND	Power ground	Connect to the negative pole of power supply
5Black	GND	Power ground	Without our power adapter, this ground wire is recommended to be reliably grounded to make the system more stable.

Table 5-4 Interface Definition of Top Configuration Type

- Note:**
1. In order to prevent the start-stop button on the touch screen from being accidentally touched, it is necessary to hold a certain area during operation and long press to trigger.
 2. If the user who purchases the top configuration type does not use our matching power supply, it may cause interference to the operation of the pump. Reliable grounding helps improve operational reliability!
 3. If the wire sequence color of the accessory wires does not correspond to the table, please check the cable definition and connect according to the sequence!

There are two speed control modes for the top configuration type: (1) LCD speed control and (2) frequency speed control. The following is the wiring instruction for the two speed control methods.

1. Wiring Instruction Using LCD Touchscreen

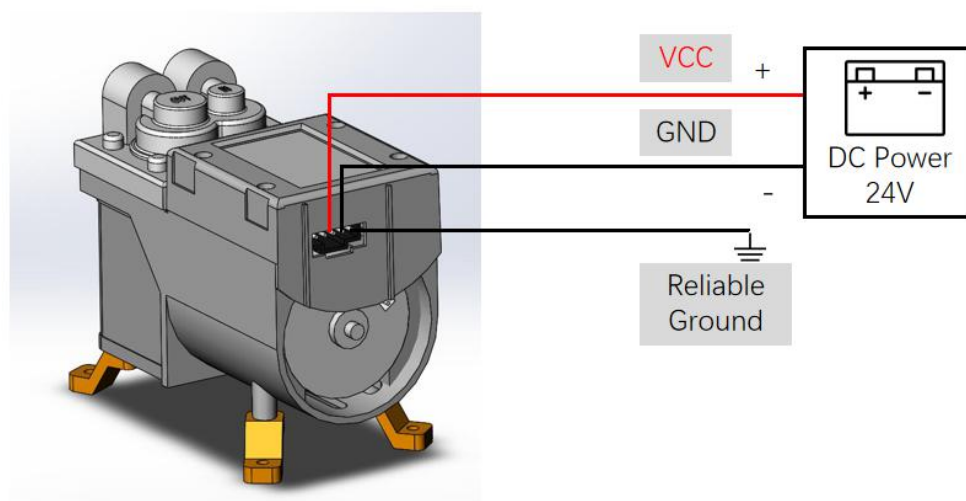

Figure 5-6 Wiring Instruction Using LCD Touchscreen

The red wire at the power connector is connected to the positive pole of the 24V DC power supply, and the black wire is connected to the negative pole of the power supply. Control the pump operation by controlling the LCD screen.

- Note:**
1. In order to prevent the start-stop button on the touch screen from being accidentally touched, it is necessary to hold a certain area during operation and long press to trigger.
 2. If the user who purchases the top configuration type does not use our matching power supply, it may cause interference to the operation of the pump. Reliable grounding of Pin-5 wire helps improve operational reliability!

2. Wiring Instruction Using Frequency Speed Control

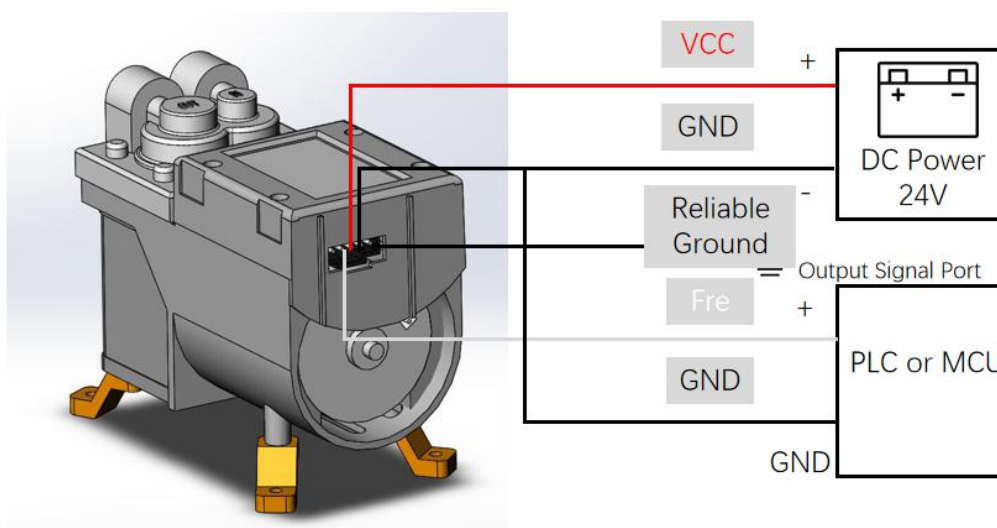

Figure 5-7 Wiring Instruction Using Frequency Speed Control

The red wire at the power connector is connected to the positive pole of the DC power supply, and the black wire is connected to the negative pole of the power supply. If not using our standard adapter, this ground wire is recommended to be reliably grounded to make the system more stable. Fre is connected to the frequency signal output port of the PLC or MCU, and GND is connected to the grounding port of the MCU or PLC. Control the pump running speed by adjusting the frequency of the square wave.

3. Frequency Signal Definition

The signal frequency 700hz-3100Hz corresponds to motor speed of 700-3100rpm, when $100 < \text{frequency} < 700\text{Hz}$, it runs at the minimum speed, when $\text{frequency} > 3100\text{Hz}$, it runs at the maximum motor speed, and when the $\text{frequency} \leq 100\text{Hz}$, the pump stops running.
 $3.3\text{V} \leq \text{high level amplitude} \leq 5\text{V}$

5.5 Alarms and Troubleshooting

Working Condition	Alarm definition	Error code	Possible reason	Troubleshooting
Power supply over voltage	"power" flashing	EE01	The output voltage of the DC power supply is greater than the normal voltage range.	1.Check whether the output voltage of the power supply is consistent with the product label, and power on again. 2.If there are frequent alarms, please contact customer service.
Power supply under voltage	"power" flashing	EE02	The output voltage of the DC power supply is less than the normal voltage range.	1.Check whether the output voltage of the power supply is consistent with the product label, and power on again. 2.If there are frequent alarms, please contact customer service.
Insufficient output power	"power" flashing	EE03	The output power of the DC power supply cannot meet the pump running power requirements or power supply output stability is poor.	Replace the DC power supply with higher output power. If there are frequent alarms, please contact customer service.
Abnormal motor stop	"motor" flashing	EE31	Motor stall, abnormal speed feedback.	1. Check whether the pipeline load is normal (reduce the running load of the pump), and power on again. 2.If there are frequent alarms, please contact customer service.
Large motor speed deviation	"motor" flashing	EE32	The deviation between the actual motor speed and the set speed is too large.	1. Check whether the pipeline load is normal (reduce the running load of the pump), and power on again. 2.If there are frequent alarms, please contact customer service.

Table 5-5 Fault Code Definition of Top Configuration Type

Note: 1. The above fault alarm codes are only applicable to top configuration type.

6 Cautions



Please read the instructions in this chapter carefully and follow the instructions strictly before use.

- 1. This product has no waterproof, dust-proof, and explosion-proof functions and cannot be used in flammable and explosive environments!**
- 2. Foreign matter must not fall into the pneumatic connectors, and there should be no solid particles in the medium, otherwise it will damage the micro pump!**
- 3. When this product is used to transfer harmful medium, it must be double-sealed to ensure personal safety!**
- 4. The matching piping components and containers must have sufficient strength to ensure personal safety!**
- 5. Built-in precision control circuit, need to use high-quality DC power supply to power the pumps!**
- 6. If this series of pumps do not use the matching power supply, it may cause interference to the operation of the pump. Please follow the instructions strictly!**
- 7. Before wiring, the user should ensure that the input voltage is 24V or 12V according to the nameplate label. The wrong input voltage will cause damage to the product and is not covered by the warranty.**
- 8. Oil mist, high-viscosity liquids and liquids that are easy to precipitate and crystallize are not permissible!**
- 9. Please operate strictly in accordance with the requirements of this user guide!**

7 Dimensions

Overall Dimensions
of C30 Basic Type
(unit:mm)
Outline Drawing
without Connectors

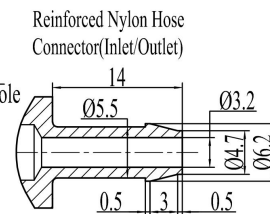
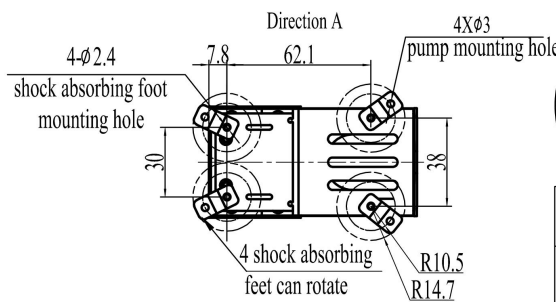
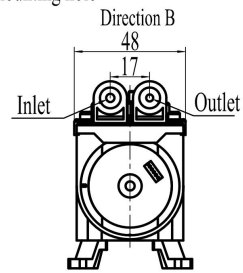
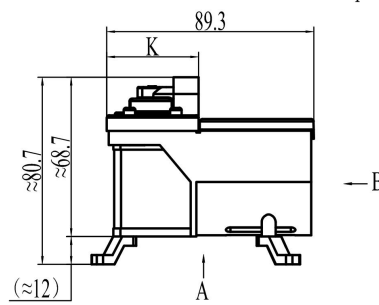
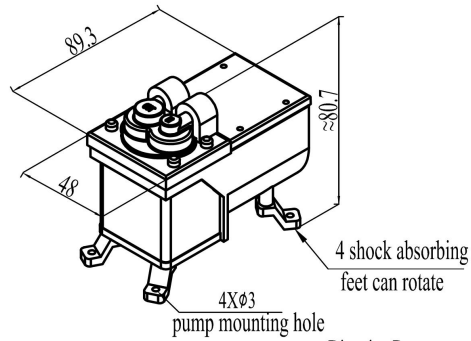

Type of Connectors	K value
no connector	≈90.8
Push-in Connector	6mm 90.8+X(≈105 ^①) 8mm 90.8+X(≈107 ^②)
Stainless Steel Hose Connector	90.8+Y(≈108 ^③)
Reinforced Nylon Hose Connector	90.8+Z(≈108 ^④)

Size of ①②③④ is related to the pneumatic connectors and its installation dimensions, for reference only, the error may be a few millimeters

Overall Dimensions of
C30 Knob Speed Control
Type/Frequency Speed
Control Type (unit:mm)
Outline Drawing without
Connectors

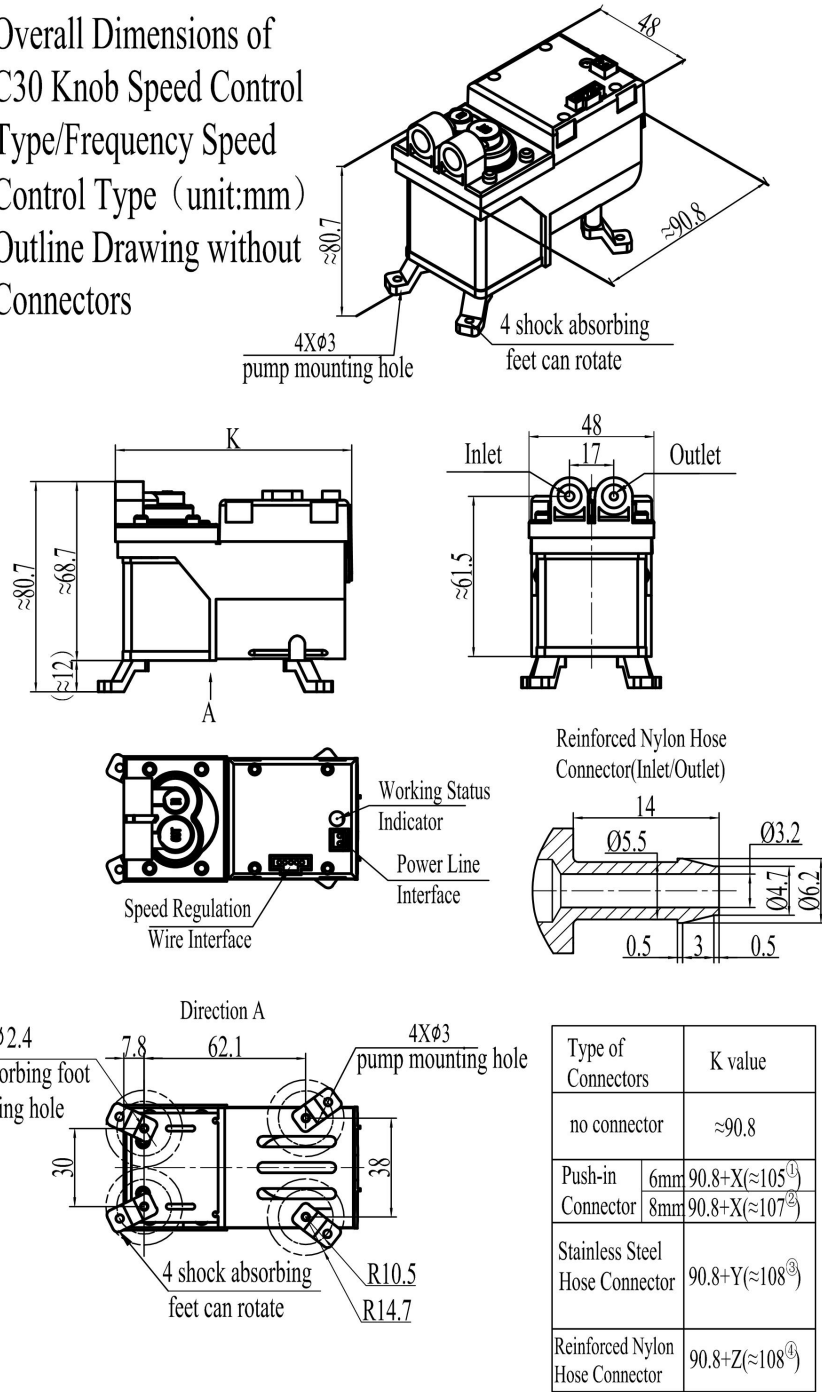

Size of ①②③④ is related to the pneumatic connectors and its installation dimensions, for reference only, the error may be a few millimeters

Overall Dimensions of
C30 Top Configuration
Type (unit:mm)
Outline Drawing Without
Connectors

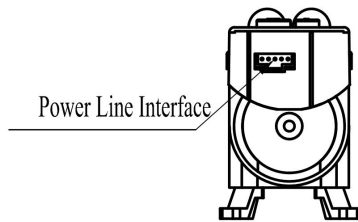
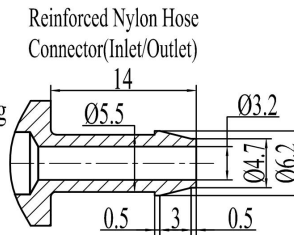
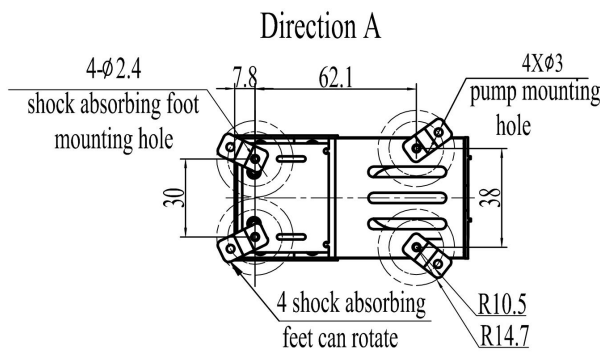
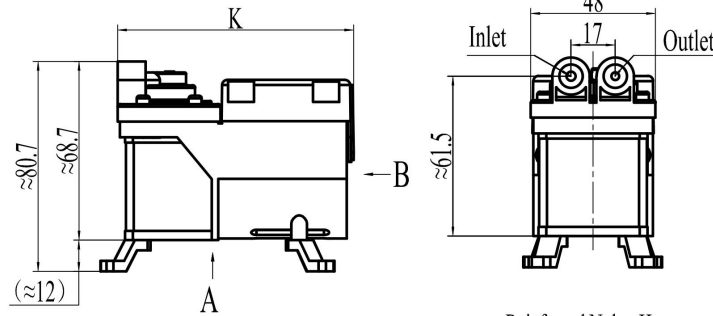
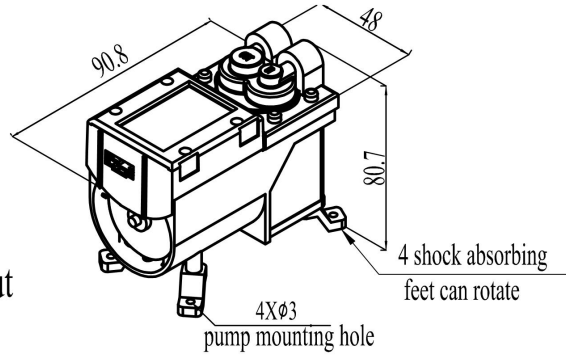

Type of Connectors	K value
no connector	≈90.8
Push-in Connector	6mm 90.8+X(≈105 ^①)
	8mm 90.8+X(≈107 ^②)
Stainless Steel Hose Connector	90.8+Y(≈108 ^③)
Reinforced Nylon Hose Connector	90.8+Z(≈108 ^④)

Size of ①②③④ is related to the pneumatic connectors and its installation dimensions, for reference only, the error may be a few millimeters

Installation instructions:

1. The screws on the pump cannot be removed, otherwise it will damage the pump;
2. The mounting holes are self-tapping screw holes, not suitable for repeated tightening and disassembly, otherwise the installation will be loose and unreliable.

8

Appearance

C30 Top Configuration Type

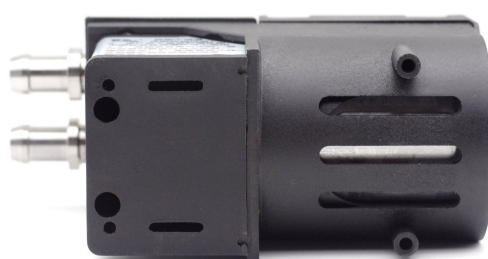

C30 Frequency Speed Control Type Knob Speed Control Type

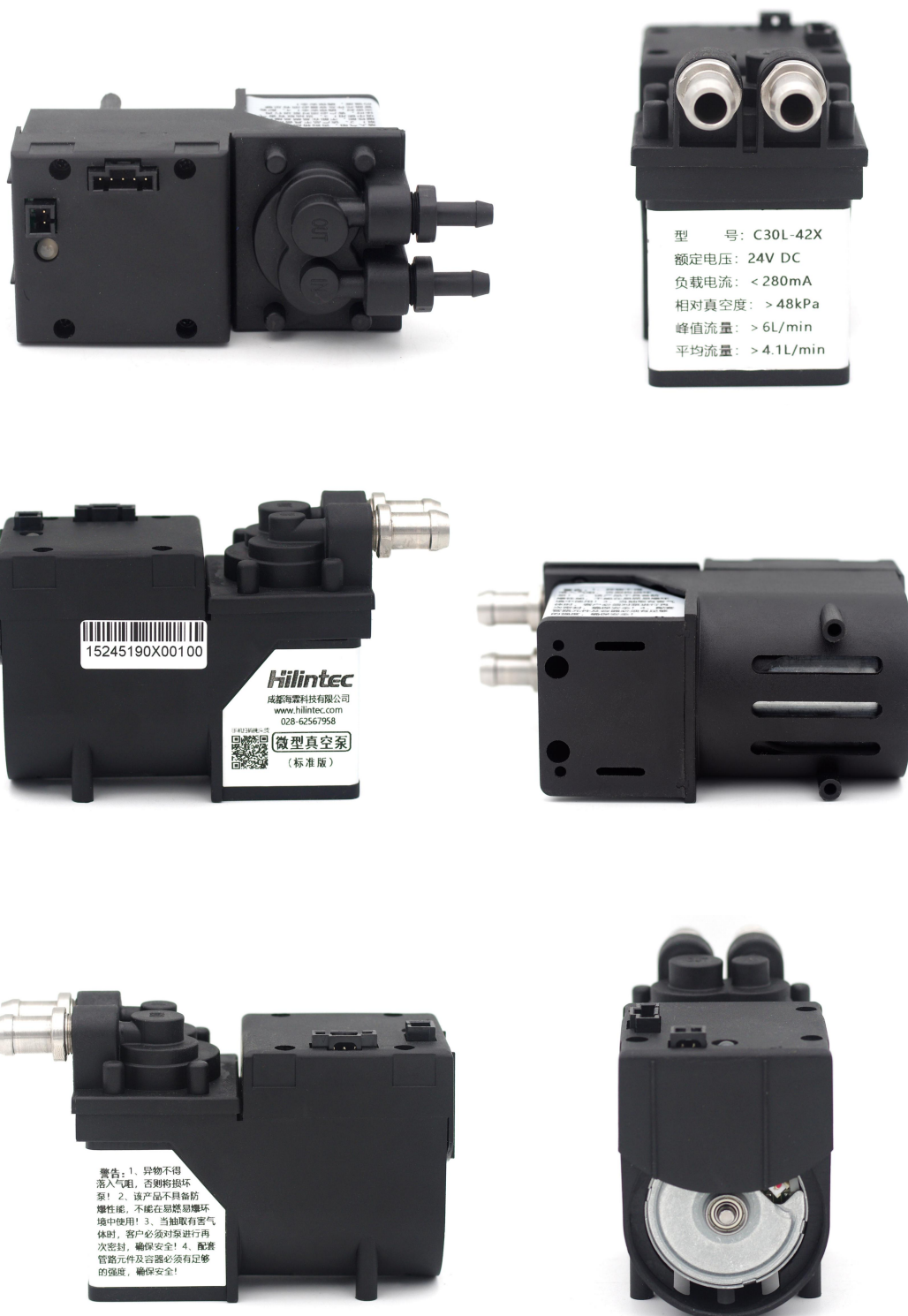

C30 Basic Type



Note: The appearance of the above-mentioned hydraulic connector differs with optional configurations.